

Operating manual and technical data

HAMMER MILL OM-HM-700

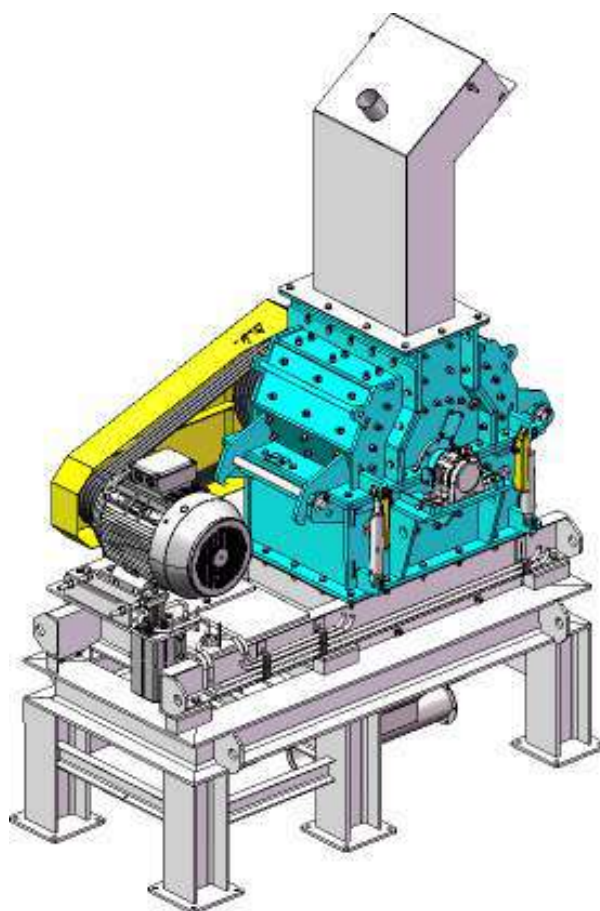



2021

1

INDUSTRY MACHINERY

HAMMER MILL OM-HM-700



1 TABLE OF CONTENTS

- 1 Safety4
 - 1.1 Safety warnings (warning notes)5
 - 1.1.1 Classification of hazards:5
 - 1.2 Ideograms for mandatory work safety measures6
 - 1.3 Proper use7
 - 1.4 Possible dangers caused by machinery8
 - 1.5 Qualification of personnel9
 - 1.5.1 Target group9
 - 1.6 Safety devices10
 - 1.6.1 EMERGENCY button10
 - 1.6.2 Protective covers11
 - 1.6.3 Safety switch11
 - 1.7 Warning and information labels12
 - 1.8 Safety check13
 - 1.9 Individual protection gear13
 - 1.10 Safety during operation13
 - 1.11 Safety during maintenance14
 - 1.11.1 Disconnect machine14
 - 1.11.2 Mechanical maintenance work14
 - 1.12 Electrical system15
 - 1.13 Lifting equipment15
 - 1.14 Accident report15
- 2 Technical data16
 - 2.1 Characteristic plate16
 - 2.2 Technical machine data16
- 3 Design and function17
- 4 Handling19
 - 4.1 Safety19
 - 4.2 Working cycle19
- 5 Maintenance22
 - 5.1 Safety22
 - 5.1.1 Preparation22
 - 5.2 Revision and maintenance23
 - 5.2.1 Lubrication24
 - 5.2.2 Lubrication - appendix25
 - 5.2.3 Bearing mounting26
 - 5.2.4 SPB belt mounting27
 - 5.2.5 Bearing mounting - appendix28
- 6 Main components assembly29



TABLE OF CONTENTS

6.1.1 Assembly drawings - appendix.....30

7 Wiring diagram 31

8 Machinery drawings 32

9 Appendix 33

9.1 Copyright.....33

9.2 Warranty.....33

9.3 EC Declaration of Conformity..... 34

9.4 General maintenance table35

10 Data sheets.....40

1 Safety

This section of the operating manual:

- Explains the meaning and use of the warning references contained in the operating manual,
- States the instructions with regard to the operation of the machinery,
- Warns you on the dangers to you and third parties, which could occur in the event the instructions in this manual are not observed,
- Informs you on measures that help prevent hazard.

In addition to this operating manual please observe

- Applicable laws and regulations,
- Legal regulations for accident prevention,
- The danger, warning and mandatory signs such as warning reference on this kind of machinery.

During installation, operation, maintenance and repair of machinery the EU standards must be observed.

With regard to relevant national legislation which has not yet been adjusted to the EU standards, the applicable national legislation is to be observed.

THE DOCUMENTATION MUST BE KEPT NEAR THE MACHINERY, FOR POSSIBLE FUTURE REFERENCE.



INFORMATION

In the event this operation manual does not offer a solution to your problem, please feel free to contact:

OMECHA UAB

J.Basanavicius al.26-20



LT-50273, Kaunas Lithuania

www.omecha.lt

1.1 Safety warnings (warning notes)

1.1.1 Classification of hazards:

We classify the safety warning into various levels. The table below gives an overview of the classification of symbols (pictograms) and warnings for the specific danger and its consequences.

Ideogram	Warning alert	Definition
	DANGER!	Imminent danger that will cause serious injury or death to person
	WARNING!	Risk: a danger that might cause serious injury or death to person
	CAUTION!	Danger or unsafe procedure that might cause injury to person or damage to property
	ATTENTION!	Situation that could cause damage to the machinery, to the product and other types of damages No risk of injury to person
	INFORMATION	Application advice and other important or useful information and notes No dangerous or harmful consequences for person or objects

In case of specific dangers we replace the ideogram:



General danger to:



Hazardous electrical voltage



Injuries to hands



Rotating parts



Blasting parts

1.2 Ideograms for mandatory work safety measures

In case of specific dangers we replace the ideogram:



Use safety glasses! Risk of eye injury



Use safety helmet! Risk of head injury



Use respiratory mask! Risk of lung injury



Use ear protection! Risk of ear injury



Use protective gloves! Risk of limb injury



Use protective boots! Risk of limb injury



Pull the main plug!



Switch off main power supply!

1.3 Proper use



WARNING!

Improper use of machinery:

- *will endanger personnel,*
- *will endanger the machinery and other items used by the operator,*
- *may affect proper operation of the machinery.*

The machinery is designed and manufactured to be used in environments in which there is no potential danger of explosion.

The machinery is designed and manufactured to crush and pulverize bulk products (stone, lime stone, ceramic, grain, waste, recyclable products). **Hammer mill** must be used with upper inlet and lower outlet which protect working zone from outside.

If machinery is used in any way other than as described above, if it is modified without the authorization of *Omecha* or if it is operated with different products, then it is being used improperly.

Omecha do not take liability for damage caused by improper use.

Any modifications to the construction, or technical or technological modifications which have not been authorized by *Omecha* will also render the guarantee null and void.

It is also part of proper use that:

- the instruction manual is observed,
- review and maintenance instructions are observed.

 see „Technical data“ chapter on page 16



WARNING!

Very serious injury.

*It is forbidden to make any modifications or alterations to the operating values of the **Hammer mill**. These could endanger personnel and cause damage to the machinery.*

1.4 Possible dangers caused by machinery

The **Hammer mill** has undergone a safety inspection (analysis of danger with assessment of risks). Design and construction based on this analysis were carried out. Nonetheless, there remains a residual risk when machinery is operated:

- with electrical voltage and current,
- with rotating parts.

If **Hammer mill** is used by personnel who are not duly qualified, there may be a risk resulting from incorrect operation or unsuitable maintenance.

Possible dangers can be present during the whole life cycle of the machinery. Danger can be present with human and machinery interaction while:

- setting;
- testing;
- start-up the machinery;
- stopping the machinery (including in case of emergency);
- recovering of operation from jam or blockage;
- cleaning and housekeeping;
- maintenance;



INFORMATION

All personnel involved in assembly, commissioning, operation and maintenance must:

- be duly qualified,
- follow this instruction

manual. Improper use:

- will endanger personnel,
- will endanger the machine and other objects,
- may affect proper operation of machinery.



WARNING!

THE MACHINERY MAY ONLY BE USED WITH SAFETY DEVICES ACTIVATED

Disconnect machinery whenever you detect a failure in the safety devices or when they are not fitted!

All additional installations carried out by the operator must incorporate the prescribed safety devices.

As the machine operator, this will be your responsibility!

 see „Safety devices“ chapter on page 10

1.5 Qualification of personnel

1.5.1 Target group

This manual is addressed to:

- operators,
- users,
- maintenance staff.

The warning notes therefore refer to both operation and maintenance of *Hammer mill*.

Determine clearly who will be responsible for the different activities on the machine (use, maintenance and repair)

Vague or unclear assignment of responsibilities constitutes a safety hazard!



Always disconnect the machine from main power supply. This will prevent it being used by unauthorized personnel.

Authorised personnel



WARNING!

Incorrect use and maintenance of machinery can cause danger for personnel, objects and the environment.

Only authorized personnel may operate machinery !

Personnel authorized to use and perform maintenance are the trained and instructed technical staff working for the operator and manufacturer.

The operator must

- train staff,
- instruct staff regularly (at least once a year) on
 - all safety standards that apply to the machine,
 - operation,
 - accredited technical guidelines.
- document training/instruction,
- check whether the staff are aware of safety and of dangers in the workplace and whether they observe the instruction manual.

The user must

- have received training in operation of machine,
- know the function and principle of operation,
- before the machine is first used
 - have read and understood the instruction manual,
 - be familiar with all safety devices and regulations.



INFORMATION

In case a main plug is provided with machinery, it must be freely accessible

1.6 Safety devices

Use *Hammer mill* only with properly functioning safety devices

Stop machine immediately if there is a failure in the safety device or if it gets ineffective It is your responsibility!

If a safety device has been activated or has failed, the machinery must only be used when:

- the cause of the failure has been removed,

it has been verified that there is no resulting danger for personnel or objects



WARNING!

If you bypass, remove or override a safety device in any other way, you are endangering yourself and other personnel working with machinery.

Hammer mill includes the following safety devices:

- EMERGENCY button,
- Protective cover for the V-belts.
- Protective cover for balance pulley.
- Safety switch between lower and upper body.

1.6.1 EMERGENCY button

The EMERGENCY button turns off the machinery. The power circuit is cut-off



INFORMATION

After switching on, turn the EMERGENCY button clockwise to enable the machine to be started.

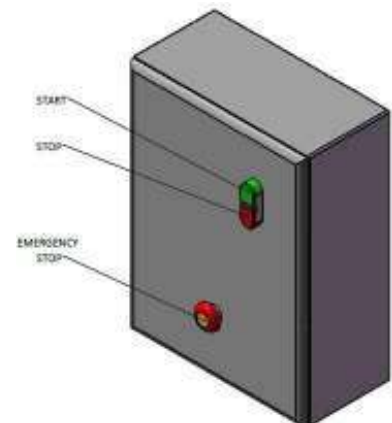

1.6.2 Protective covers

Protective V-belt cover is fitted firmly and screwed on frame. It covers balance pulley V-belt and pulleys rotational path from any mechanical damage.

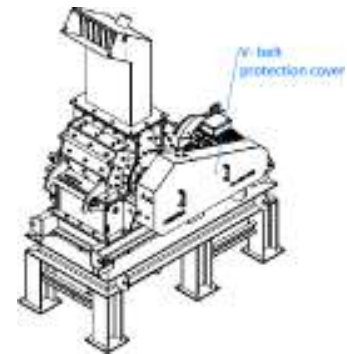

Protective axis cover is fitted firmly and screwed on frame. It covers rotating axis, and minimizes risk of an injury.

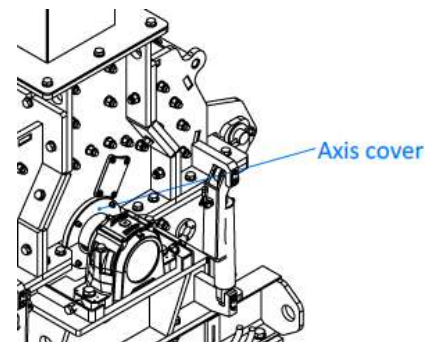

WARNING!

Danger of injury! V-belt can pull limbs or work clothes into pulley and crush persons limbs.

Take great care when removing the cover to change the belts.

Do not wear clothes with loose sleeves. Main power switch must be turned off during this operation!

1.6.3 Safety switch

Safety switch is fitted firmly and screwed between lower and upper frame connection. Safety switch cut-off electric circuit and stop electric motor when upper frame is lifted.



WARNING!

Danger of injury! It is forbidden to switch off or otherwise take out safety switch. Not following this warning can cause very serious injury to personnel.

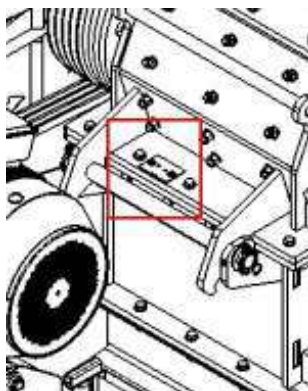

1.7 Warning and information labels



INFORMATION

All warning labels must be legible

Check them regularly

Position of labels on machine

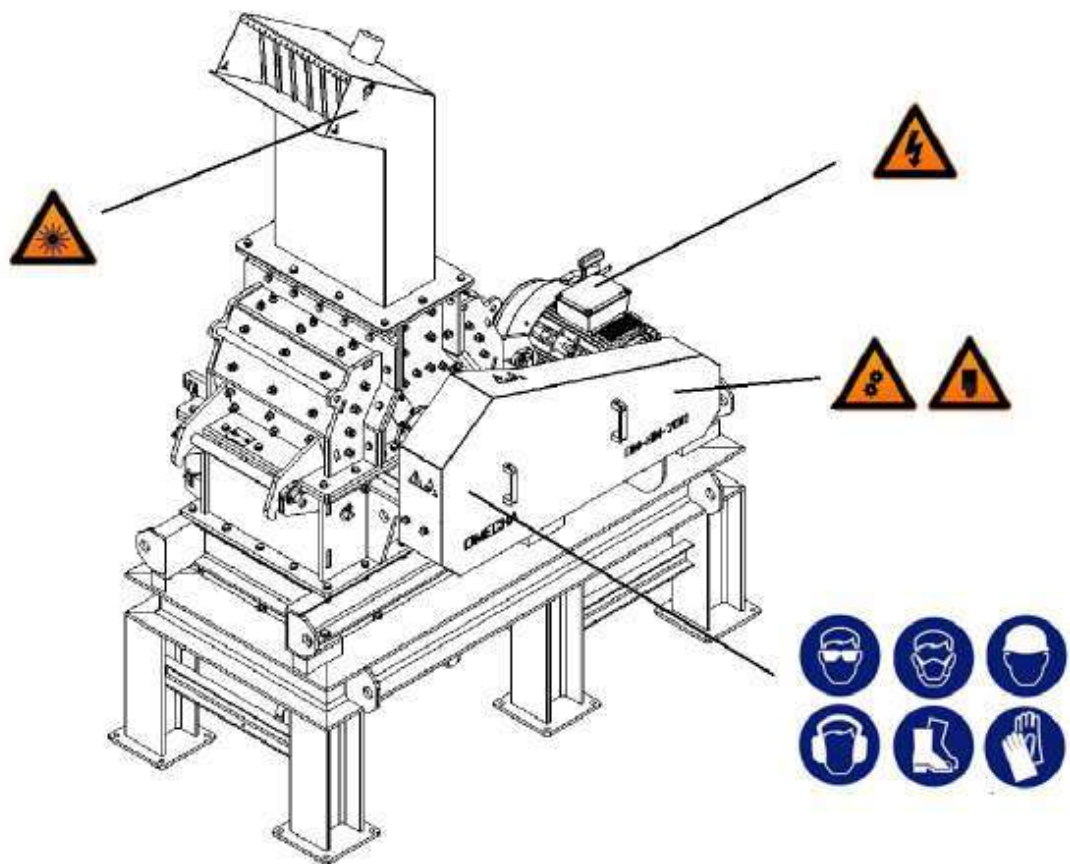

1.8 Safety check

Check *Hammer mill* at least once per shift. Inform the person responsible immediately of any damage, defect or change in operating function.

Check all safety devices:

- At the beginning of each shift (with the machine stopped)
- Once a week (with the machine in operation)
- After every maintenance and repair operation

Check that warning and information labels and markings:

- Can be identified (if not – clean them)
- Are complete



INFORMATION

 Use the given example table for checking. See „General maintenance table“ on page 35

1.9 Individual protection gear

For specific work, equipment for personal protection as protection equipment is required. This includes:

- A safety helmet,
- Protective goggles or face guard,
- Upper clothes without any loose sleeves and strings.
- Safety gloves,
- Safety shoes with steel toe cap,
- Ear protection.

Before starting work check that the proper gear is available in the workplace

1.10 Safety during operation

In the description of work with machinery we highlight the dangers specific to that work **WARNING!**



*Prior to activating **Hammer mill** please double-check whether this will:*

- *not lead to any danger with respect to people*
- *not cause any damage to equipment.*

Avoid unsafe working practices:

- check that no one can be endangered as a result of the work to be initiated.
- The instructions in this manual must be observed during assembly, handling, maintenance and repair.
- Do not work with machine if your concentration is reduced, because you take medicine.
- Observe the rules for preventing accidents issued by your association for the prevention of occupational accidents and safety in the workplace or other inspection authorities.
- Stay at the machine until all rotating parts have come to a halt.
- Use prescribed protection gear. Make sure to wear a well-fitting work suit.
- Inform the inspector of any danger or failure.

SAFETY

1.11 Safety during maintenance

1.11.1 Disconnect machine



INFORMATION

Unplug the machine from the main power source before beginning any maintenance or repair work. Place a warning sign on the machine

1.11.2 Mechanical maintenance work

Remove all protection and safety devices before beginning maintenance work and re-install them once the work has been completed. These include:

- Covers
- Safety indicators and warning signs
- Earth (ground) connection.

If you remove protection or safety devices, refit them immediately after completing the work.

Check that they are working properly!

Inform operators timely on maintenance and repair work.

Report all safety relevant changes or performance details of the machine. Document all changes, have the operation manual changed accordingly and train the machine operators.



Always use safety hydraulic cylinder lever to lock top of the mill while checking inside components.

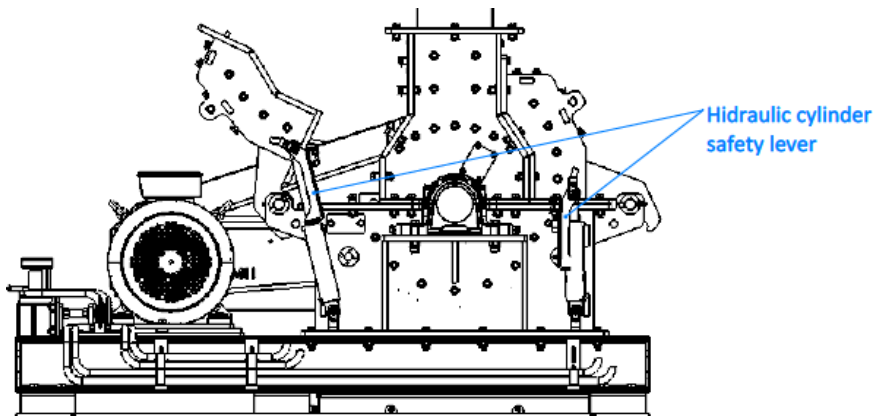

1.12 Electrical system

Have the machine and/or the electric equipment checked regularly, and at least every six months.

Eliminate immediately all defects such as loose connections, defective wires etc.

A second person must be present during work on live components, to disconnect the power in the event of an emergency

Disconnect machine immediately if there are any anomalies in the power supply!

 see „Maintenance“ chapter on page 22

1.13 Lifting equipment

WARNING!



Use of unstable lifting and load suspension gear that breaks under load can cause very serious injuries or even death.



Check that the lifting and load suspension gear

- *is of sufficient load capacity*
- *is in perfect condition*
- *has manufacturers safety standard marks*

Hold the loads properly. Never walk under suspended loads!

Hammer mill can be lifted all in one piece by lower frame hooks or separately upper frame and lower frame as shown in the picture.

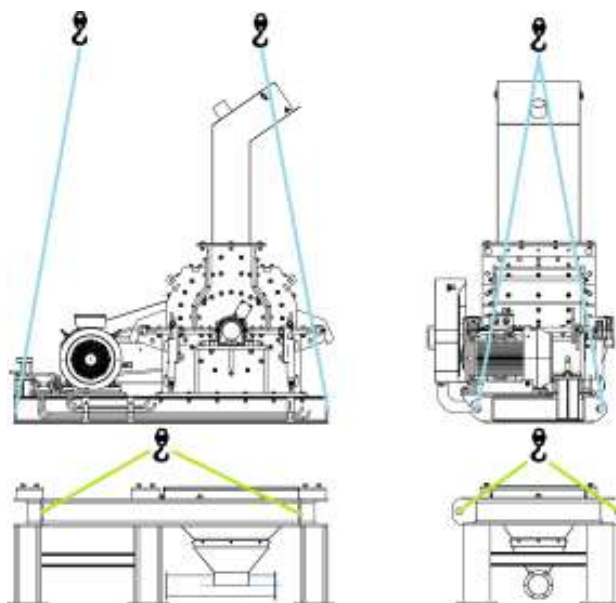

1.14 Accident report

Inform your superiors and Omecha immediately in the event of accidents, possible sources of danger and any actions which almost led to an accident.

There are many possible causes. The sooner they are notified, the faster the causes can be eliminated

2 Technical data

2.1 Characteristic plate

 	
UAB "Omega" J. Basanavicius pl. 28-29 Kaunas, Lithuania	
TITLE	<input type="text"/>
NUMBER	<input type="text"/>
DATE	<input type="text"/>
OTHER INFO	<input type="text"/>

2.2 Technical machine data

Overall dimensions		
length	2390	(mm)
width	1420	(mm)
height	3380	(mm)
Weight	3850	(kg)
Power connection		
capacity	45	(kW)
voltage	380	(V)
frequency	50	(Hz)
protection class	54	(IP)
Noise level	<70	(dB)
Working temperature	-5/+45	(°C)
Material		painted steel
main color	RAL5012	
second color	RAL7040	
third color	RAL1003	Protection, covers
Electric motor	TC_225S_B3 P-45 kW, n – 1500 rpm.	Moll electric motor
Productivity	200 - 700	(Kg)

3 Design and function

Hammer mill is used to crush various chunk pieces to fine particles- for recycling purposes.

Hammer mill crushes chunk pieces with hammers fitted on an axle inside the frame. At the bottom of the main frame there is a sieve, so fine particles are left after operation.

Machine consist of 8 main parts (when machine is fully assembled):

- electric motor (1)
- electric motor support frame (2)
- base support frame (3)
- lower mill base (4)
- upper mill base (5)
- upper intake funnel (6)
- lower funnel (7)
- ground frame (8)

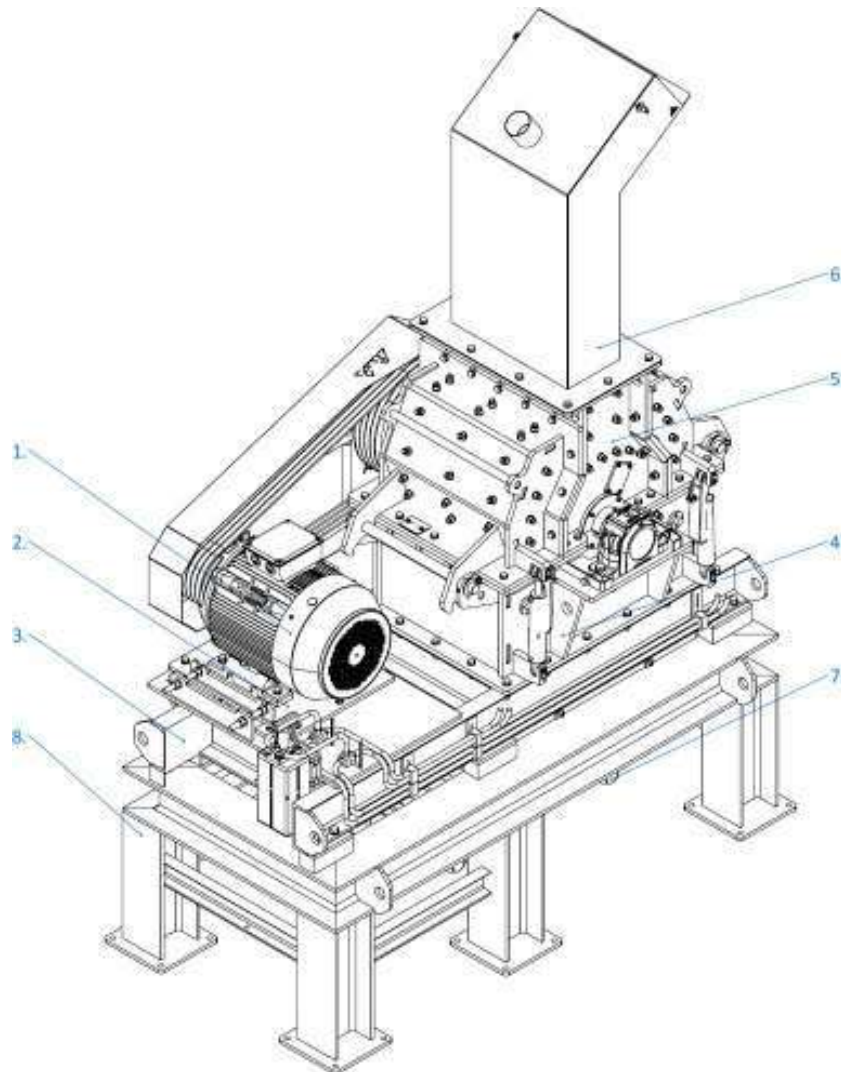

All machine components are specified in „Machinery layout“ section

 see „Machinery drawings“ chapter on page 32



WARNING!

Safe space requirements must be applied for persons interacting with the machinery, such as during operation and maintenance.

Given red line contour is a safe space zone, which must be no less than 500 mm from machinery outlines.

This safe space zone must be clear from any obstacle which prevents access to machinery, If machinery is part of production line or other machinery is assembled with it, then safe zone applies to all machines or other safety standards must be applied.

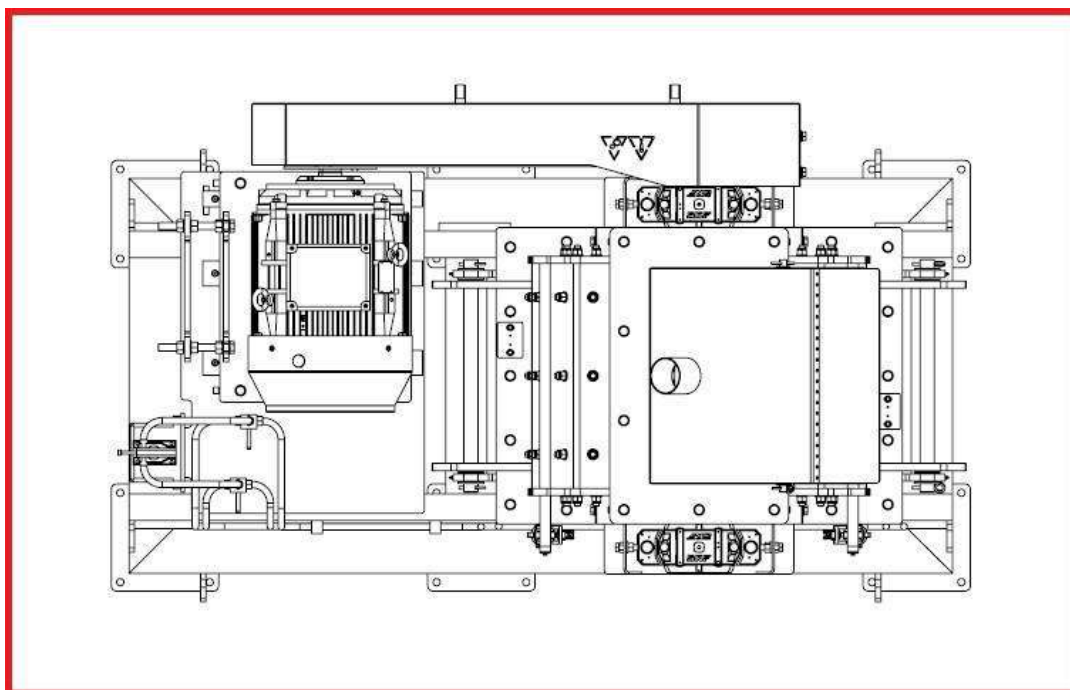

4 Handling

4.1 Safety

Use the machine only under following conditions

- the machine is in proper working order
- the machine is used as prescribed
- follow the instructions manual
- all safety devices are installed and activated

All anomalies should be eliminated immediately. Stop machine immediately in the event of any abnormality in operation and make sure it cannot be started up accidentally or without authorization.

Notify the person responsible immediately of any modification

 see „Safety during operation“ chapter on page 13

4.2 Working cycle

Machine must start working with no load or product inside.

Motor and rotating parts must reach full speed and power capacity before full operation.



WARNING!

Rotating blades must rotate in a described rotation direction. Failing to meet this instruction may cause injury to person and product capacity will not be reached

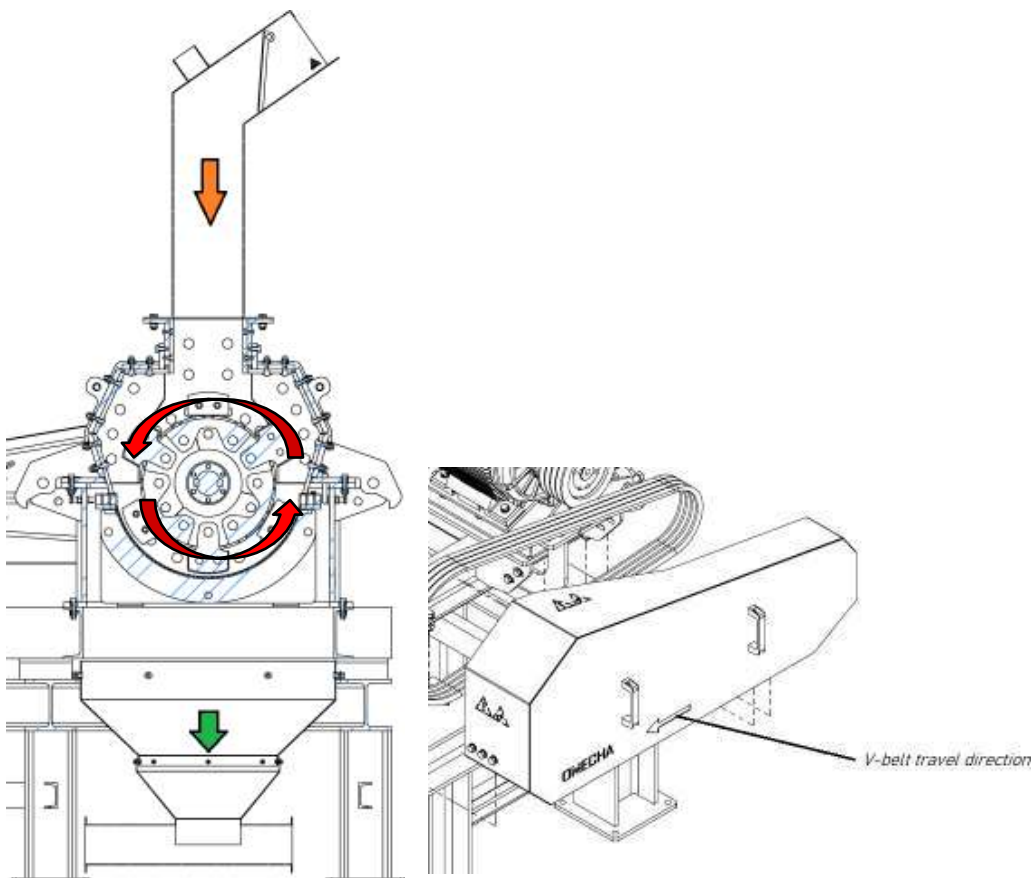

There is opportunity to use machinery in reverse working direction. For more information contact UAB „Omecha“

4.3 Maintenance lid handling

To maintain the inside components of the machinery, frame lids must be opened. Which be listed below.

WARNING!



When opening a lid no personnel should stand near, the moving lids. After the lid is fully opened use safety latches, to lock it from closing. Failing to meet this instruction will cause injury to personnel.

There are four stages of lid handling, in order to operate the hydraulic systems, there are three levers included. Two levers to operate the direction of the flow, and one lever on the oil pump:

- Stage 1 and Stage 2 (Left lid handling)
To operate left lid, flow valves should be set forward.
Oil pump valve set to left- to open the lid. Set to right- to close the lid.

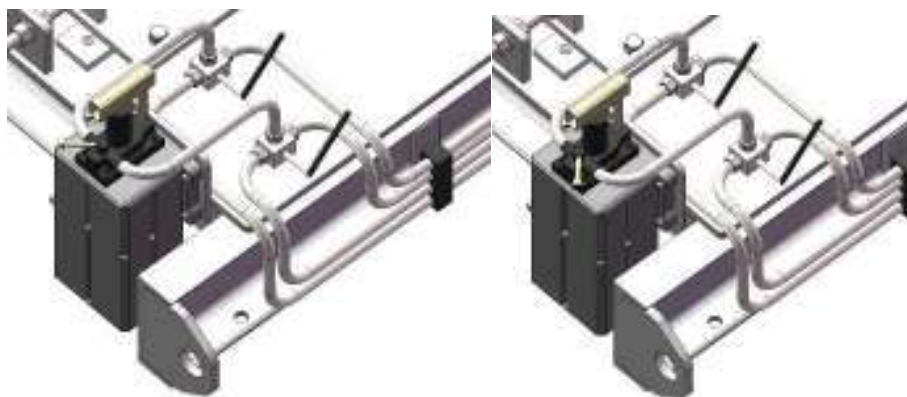

Opened left lid.

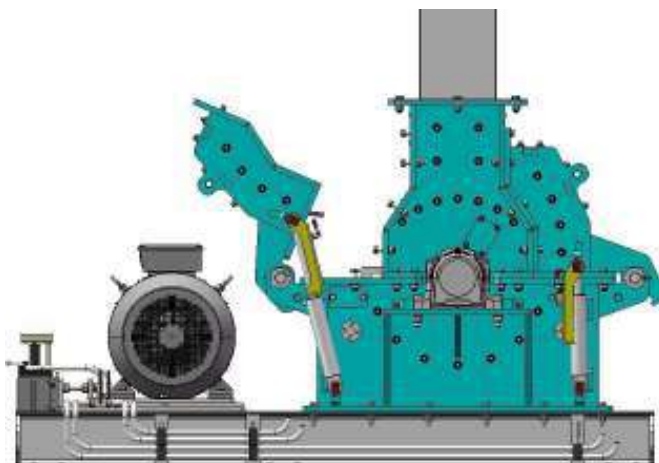

HANDLING

- Stage 3 and Stage 4 (Right lid handling)
To operate right lid, flow valves should be set backward.
Oil pump valve set to left- to open the lid. Set to right- to close the lid.

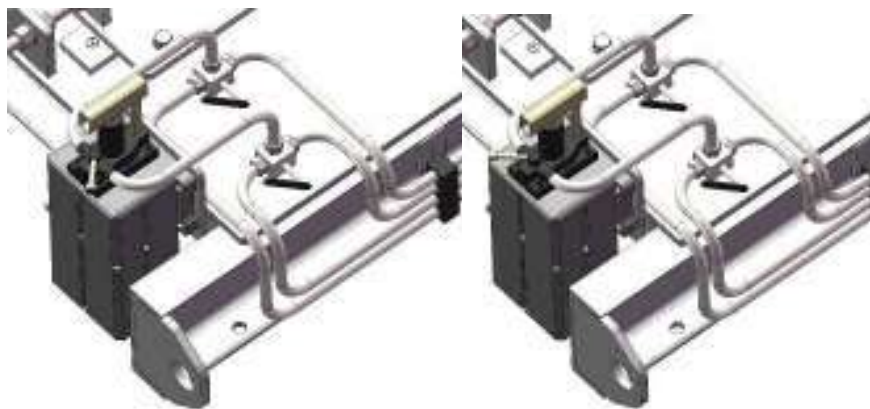

Opened right lid.

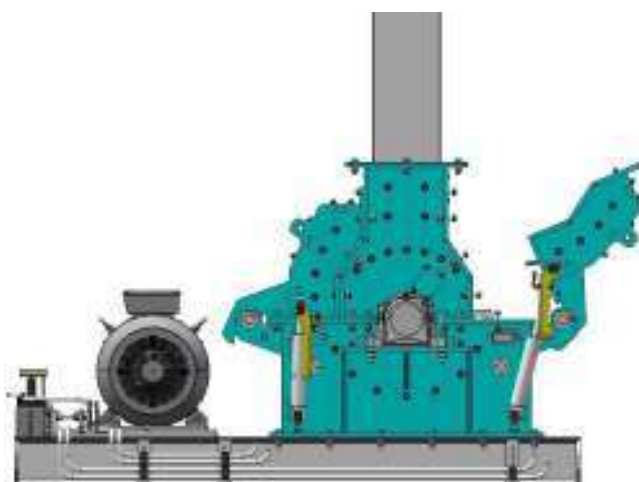

5 Maintenance

In this chapter you will find important information about

- inspection
- maintenance
- repairs

of *Hammer mill*



NOTICE!

Properly-performed regular maintenance is essential prerequisite for

- safe operation
- fault-free operation
- long service life of machinery
- the quality of the products you manufacture

5.1 Safety



WARNING!

The consequences of incorrect maintenance and repair work may include:

- *very serious injury to personnel working with machine*
- *damage the machine*

Only qualified personnel should carry out maintenance and repair work on the machine. Use the prescribed protection equipment.

5.1.1 Preparation



WARNING!

Only carry out work on the machine if it has been unplugged from main power source.

 see „Safety“ chapter on page

4 Position a warning sign.



5.2 Revision and maintenance

The type and extent of wear depends to a large extent on the individual usage and service conditions. For this reason, all the intervals are only valid for the authorized conditions.

INTERVALS	PART	WHAT TO DO
Every 3 month of operation	Pins, bolts	Check for loosen parts, tight them if needed
	Bearings	Check if they emit different sounds than in normal operating cycle, are they getting hot. Change if needed. Bearings must be lubricated with bearing grease
	Belt, chain	Check for loose drive chain belt, strained if there is looseness
	Gearmotor	check whether there are traces of grease runoff on gearmotor
Every 6 month of operation	Gearmotor	Check and run gear and motor, check that it does not emit any different sounds than in normal operating cycle
	Pulleys, sprockets	check whether chain belt is worn, sprockets sheave worn out
	Belt, chain	Check if there is no rupture, fatigue signs on weld lines
	Construction	Check if there is no rupture, fatigue signs on weld lines
	Electrical	Check all electrical functions

Technical maintenance shedule table

PARTS	MAINTENANCE	OPERATING HOURS							
		8	24	40	160	480	960	2000	5000
SPB PULLEYS	Visual revise				x				
	Adjustment								
	Lubrication								
	Change to new part								x
SPB BELT	Visual revise				x				
	Adjustment				x				
	Lubrication								
	Change to new part							x	
SHAFT BEARINGS	Visual revise				x				
	Adjustment								
	Lubrication								
	Change to new part								x
HIDRAULIC CYLINDERS	Visual revise					x			
	Adjustment								
	Lubrication								
	Change to new part								
HIDRAULIC PUMP	Visual revise						x		
	Adjustment								
	Lubrication								
	Change to new part								

5.2.1 Lubrication



NOTICE!

These parts along with bearings must be lubricated every time you change the blades. Seals must be changed into new ones. Grease should be used Molykote® BR2 Plus or analog from other manufacturers

- ☞ • see „5.2 Revision and maintenance“ chapter on page 23

If worn, seals must be changed into new ones. Grease for bearings should be used Molykote® BR2 Plus or analog from other manufacturers

Chain must be lubricated with Molykote® 1122 or analog from other manufacturers

- ☞ • see „Lubrication appendix“ chapter for technical details of grease on page 25

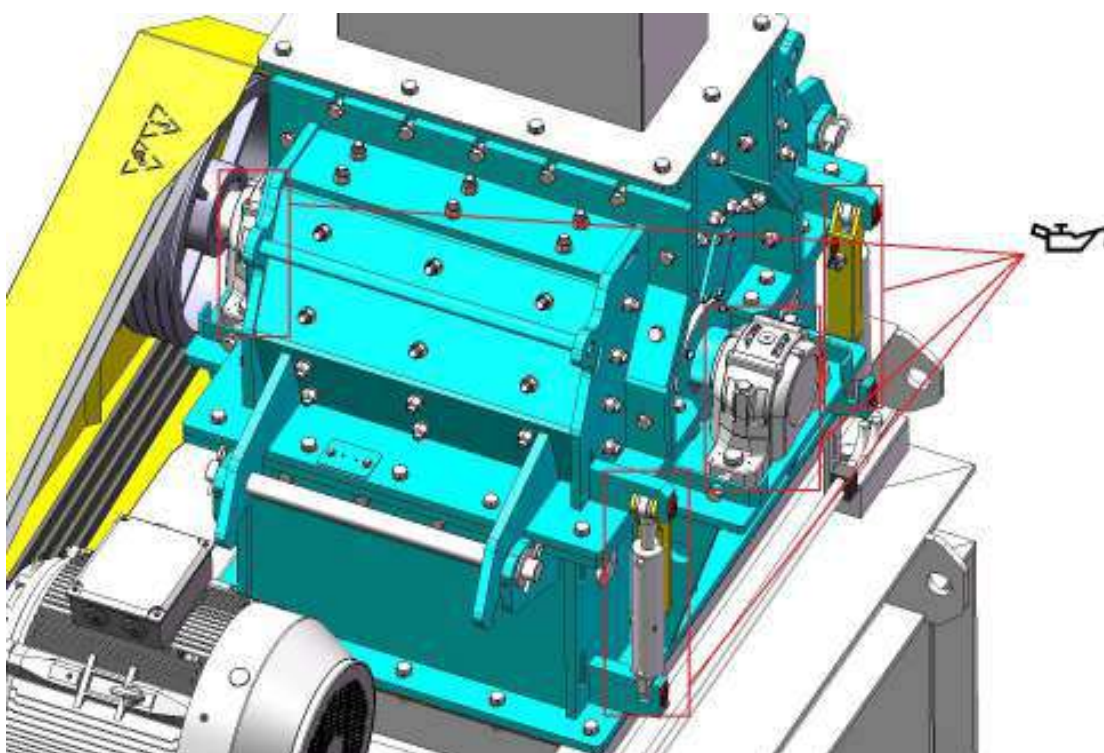

**5.2.2** Lubrication - appendix

Molykote® 1122 Chain and Open Gear Grease

APPLICATIONS

- Used for initial lubrication of chains with hollow pins equipped with grease nipples. e.g., high tenter clamp chains in the textile industry and Hammer mill chains in food sterilizer units.
- Also used for gear drives and open gears, sliding bearings operating at low speeds and high temperatures, such as bearings in drying systems and calendaring machines used in various industrial processes.

TYPICAL PROPERTIES

Specification Writers: These values are not intended for use in preparing specifications. Please contact your local Dow Corning sales office or your Global Dow Corning Connection before writing specifications on this product.

Test*	Property	Unit	Result
	Color		Black
	Temperature		
	Service temperature range	°C	10 to 160
	Unworked penetration		250-280
	Load-carrying capacity, wear protection, service life		
	Four-ball tester (VKA)		
DIN 51 350 pt.5	Wear scar under 600N load	mm	0.9
DIN 51 350 pt.4	Weld load	N	2600
	Almen Wieland machine OK load	N	18000
	Density, viscosity		
	Density at 20°C	g/ml	0.95
	Base oil viscosity at 40°C	mm ² /s	1500

HOW TO USE

Clean the contact areas. As is usual with lubricating greases, apply by means of a brush, spatula, grease-gun or automatic lubrication device.

Chains with hollow pins

The hollow pins should be completely packed with grease. Relubricate through grease nipples using a grease gun. Molykote® 1122 Chain and Open Gear Grease is effective to 160°C under these conditions.

Gears

The tooth profiles of new gears should be treated with Molykote® G-n Metal Assembly Paste and Spray and run without load for a short time to generate a basic solid lubricating film. The gears should then be lubricated with Molykote 1122 Chain and Open Gear Grease in accordance with the gear manufacturer's instructions

USABLE LIFE AND STORAGE

When stored at or below 20°C in the original unopened containers Molykote 1122 Chain and Open Gear Grease has a usable life of 60 months from the date of production.

BEARING MOUNTING

5.2.3 Bearing mounting

First step (1)

- Ensure that the environment is clean
- If the bearing is mounted on an adapter sleeve, determine the position of the housing
- Position bearing on the shaft.

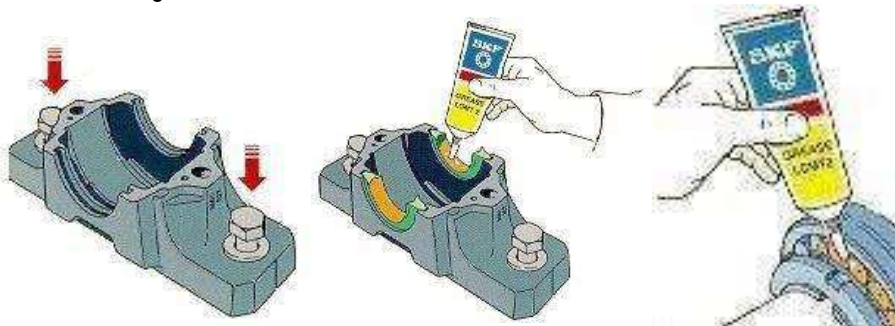

Second step (2)

- Lay the shaft with bearing in the housing base
- Carefully align the housing base

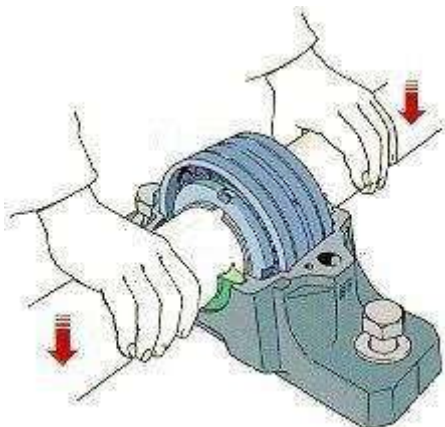

Third step (3)

- Tighten the bearing holding nuts to hammer mill lower base.
- Tighten screws on bearing sides to improve bearing stability.

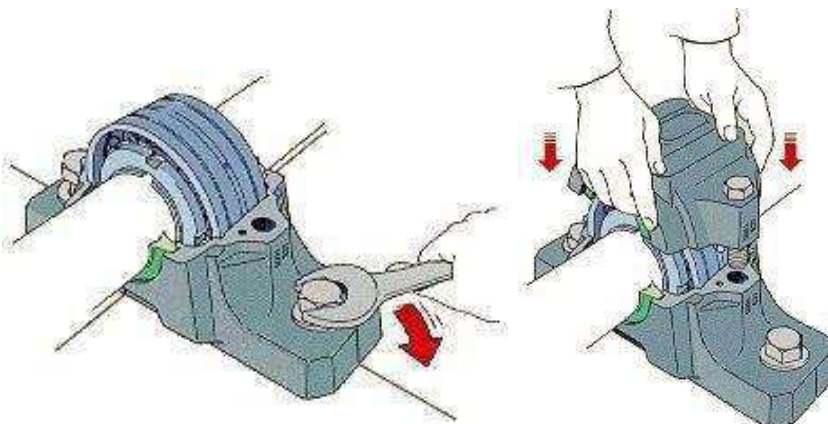

 • see „Bearing mounting - appendix“ for drawings and mounting parts on page 28

5.2.4 SPB belt mounting



NOTICE!

After maintenance check SPB belt alignment.



WARNING!

SPB belt can only be operated to both pulleys as shown in the picture above.

Check for any misalignment as shown in the pictures below:

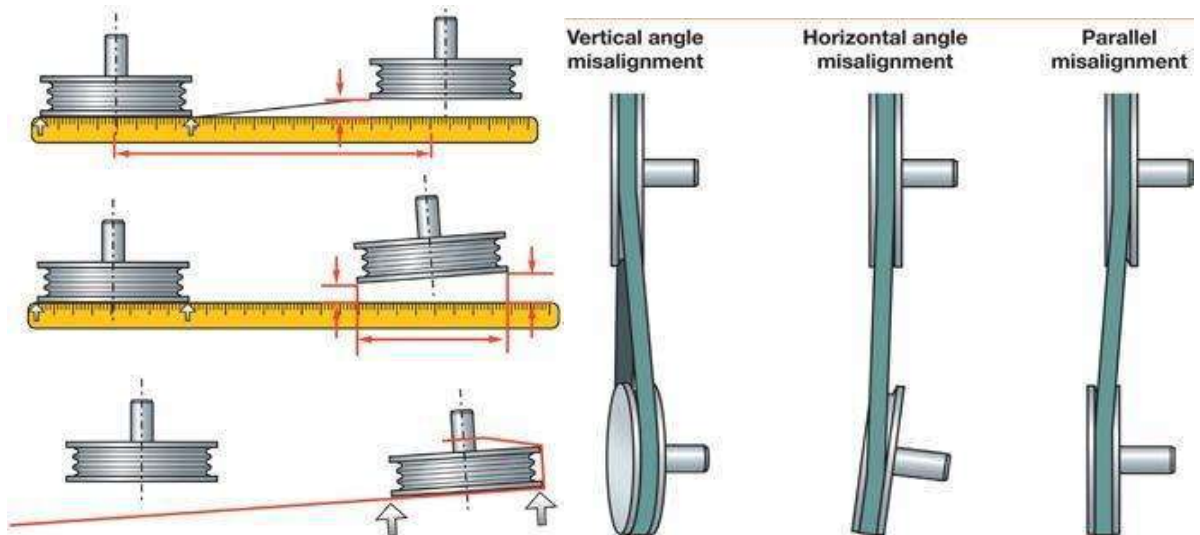



5.2.5 Bearing mounting – appendix

- see „Machinery drawings“ for more detail drawings and mounting parts on page 32

6 Main components assembly



INFORMATION!

The machinery is shipped disassembled or partly assembled

Some machinery components must be maintained and taken apart due to transport.

In this chapter some of those components assembly drawings are presented for better knowledge of machinery to personnel

 • see „Assembly drawings - appendix“ on page 30



ATTENTION!

Improper storage may cause important parts to be damaged or destroyed. Store packed or unpacked parts only in suitable places.



6.1.1 Assembly drawings - appendix

- see „Machinery drawings“ for more detail drawings and mounting parts on page 32



7 Wiring diagram



8 Machinery drawings



9 Appendix

9.1 Copyright

©2021

This document is copyright. All derived rights are also reserved.

The company reserves the right to make technical alterations without prior notice

9.2 Warranty

The term of warranty for commercial use is 12 months. Condition for a warranty claim due to construction errors, faults in material and/or defects of fabrication is:

- Proof of purchase and that the instructions for use had been followed. Damages due to operator's mistakes may not be accepted as warranty claims.
- Correct use of the machine. The warranty claim may not be accepted if the operating manual is not being followed properly.
- Maintenance work and cleaning.
- Original spare parts. Make sure to use only original spare parts and original accessory.
- Wearing parts. Certain components are subject to wear out by time respectively a standard wear by use on the corresponding machine. Among these components are V-belts, ball bearings, chains, sprockets, bushes, washers, switches, cables, etc. These wearing parts are not part of the warranty.



9.3 EC Declaration of Conformity

<i>The manufacturer</i>	Omecha UAB J.Basanavicius al.26-20 LT-50273, Kaunas Lithuania
	Hereby declares that the following product
<i>Type of machine</i>	Hammer mill
<i>Name of machine</i>	OM-HM-700
<i>Relevant EU directives</i> <i>Machinery Directive</i>	LST EN ISO 12100:2011 Safety of machinery - General principles for design - Risk assessment and risk reduction LST EN ISO 13857:2008 Safety of machinery - Safety distances to prevent hazard zones being reached by upper and lower limbs LST EN 349:1998+A1:2008 Safety of machinery - Minimum gaps to avoid crushing of parts of the human body
<i>Low voltage directive</i>	LVD 2014/35/UE Low voltage directive

Meets the provisions of these directives, including any amendments valid at the time of this statement

Tomas Teškevičius
(director) Kaunas
26/08/21



9.4 General maintenance table

No.	Date	Work done by (name, surname, signature)	Supervisor for machinery (name, surname, signature)
Type of maintenance			
The completed work description			
No.	Date	Work done by (name, surname, signature)	Supervisor for machinery (name, surname, signature)
Type of maintenance			
The completed work description			



APPENDIX

No.	Date	Work done by (name, surname, signature)	Supervisor for machinery (name, surname, signature)
Type of maintenance			
The completed work description			
No.	Date	Work done by (name, surname, signature)	Supervisor for machinery (name, surname, signature)
Type of maintenance			
The completed work description			



APPENDIX

No.	Date	Work done by (name, surname, signature)	Supervisor for machinery (name, surname, signature)
Type of maintenance			
The completed work description			
No.	Date	Work done by (name, surname, signature)	Supervisor for machinery (name, surname, signature)
Type of maintenance			
The completed work description			



APPENDIX

No.	Date	Work done by (name, surname, signature)	Supervisor for machinery (name, surname, signature)
Type of maintenance			
The completed work description			
No.	Date	Work done by (name, surname, signature)	Supervisor for machinery (name, surname, signature)
Type of maintenance			
The completed work description			



APPENDIX

No.	Date	Work done by (name, surname, signature)	Supervisor for machinery (name, surname, signature)
Type of maintenance			
The completed work description			
No.	Date	Work done by (name, surname, signature)	Supervisor for machinery (name, surname, signature)
Type of maintenance			
The completed work description			



10 Data sheets

Vaizdas A

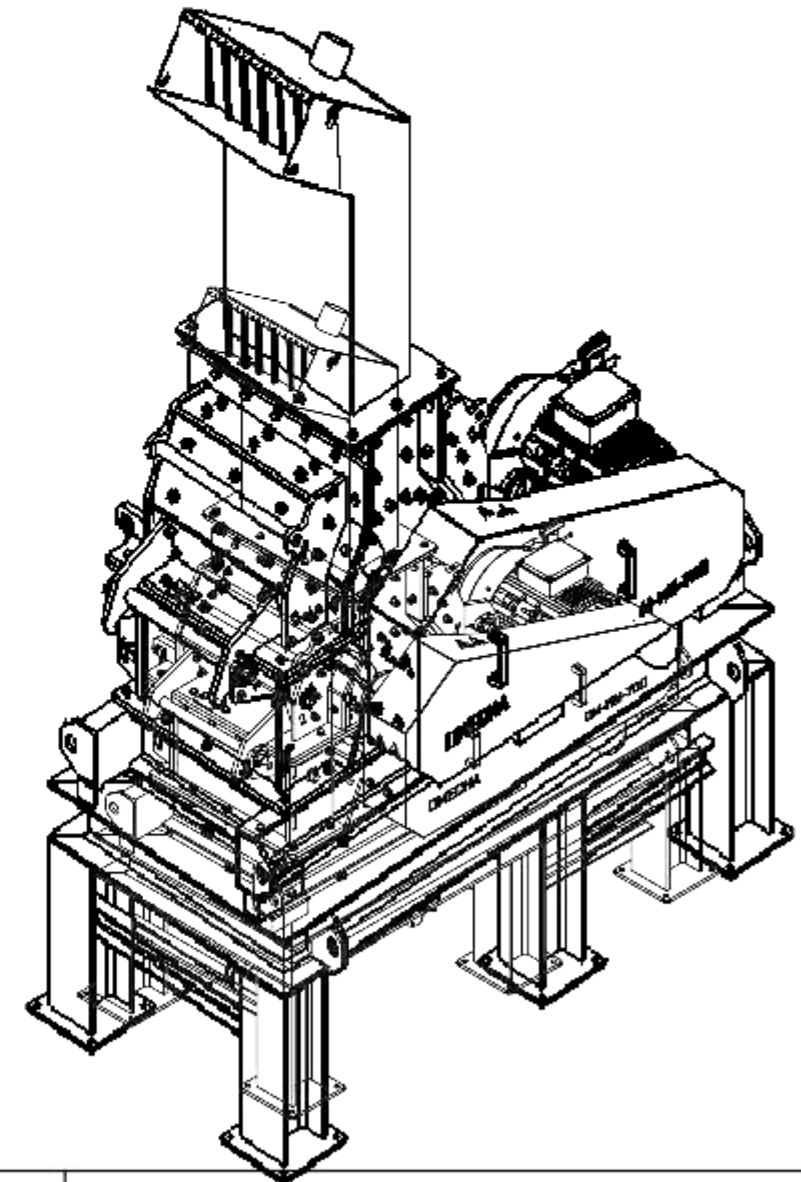
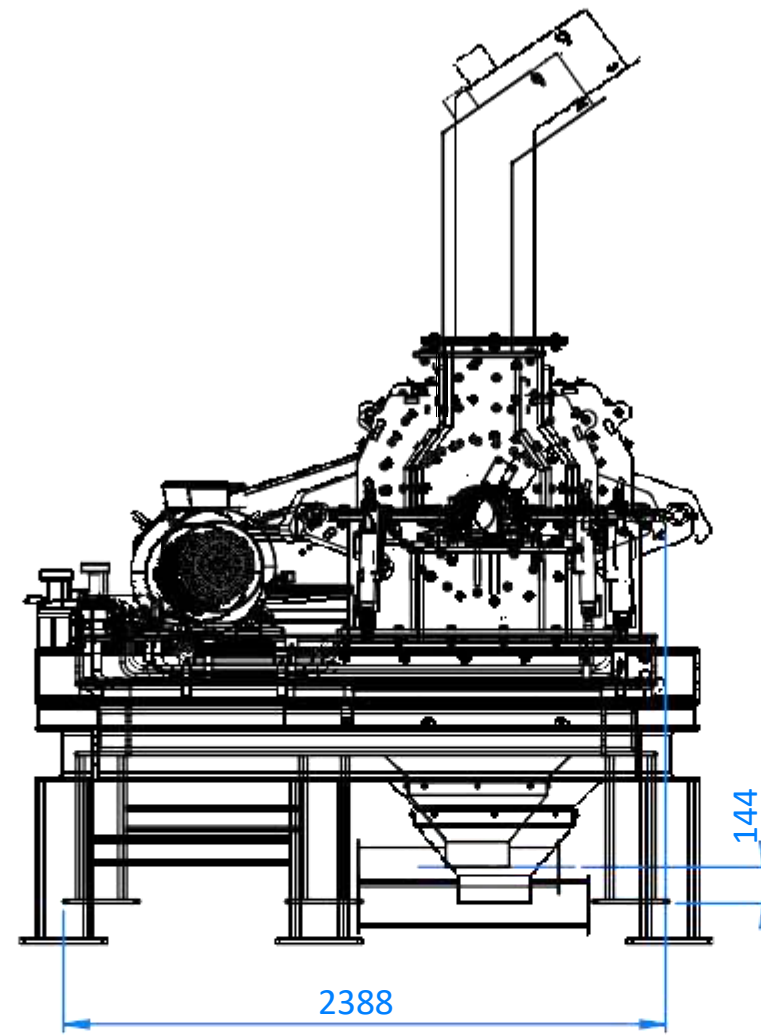
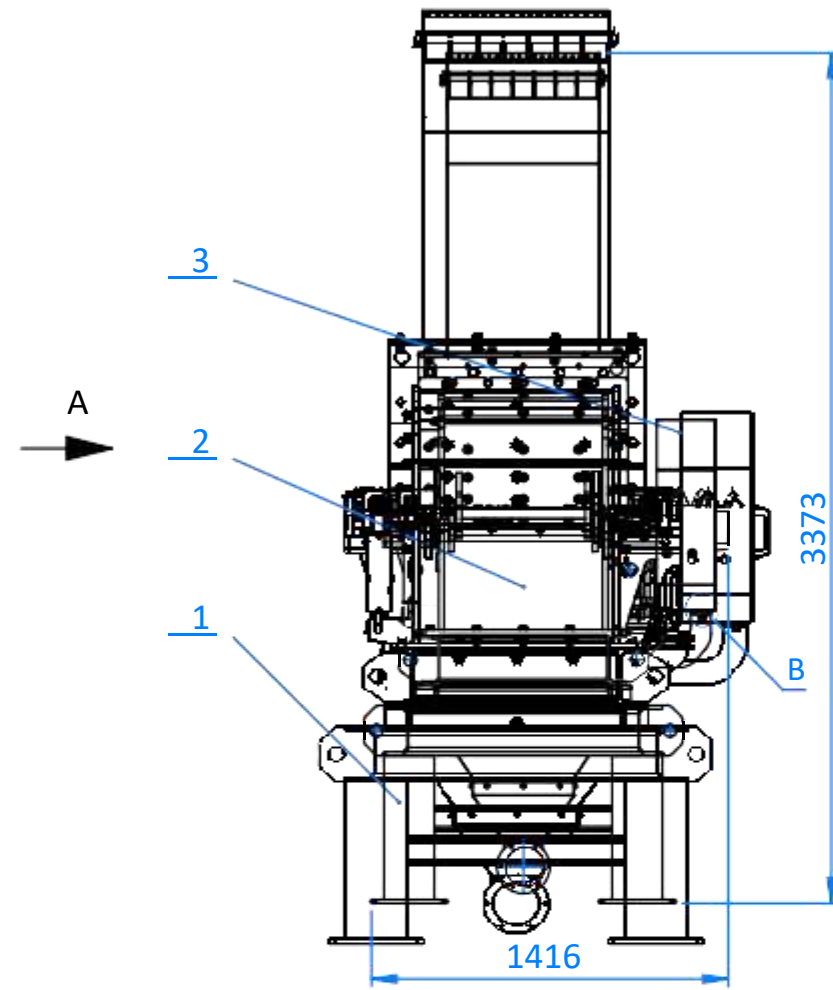

POZ.	ŽYMĖJIMAS	KONFIG.	APRAŠYMAS	KIEKIS
1	OM.72.10.00.00.00.00.00.SB	010	Žemutinis malūno rėmas	1
2	OM.72.20.00.00.00.00.00.SB	010	Plaktukinis malūnas su rému	1
3	OM.72.30.00.00.00.00.00.SB	010	Apsauga	1
4	SPC diržas C- 3426	010	Pagrindinis diržas	4
5	DIN 125 - Ø17		Poveržlė	4
6	DIN 125 - Ø21		Poveržlė	24
7	DIN 128 - A16		Spyruoklinė poveržlė	4
8	ISO 4017 M16 X 35		Varžtas	2
9	ISO 4017 M16 X 45		Varžtas	2
10	ISO 4017 M20 X 60		Varžtas	12
11	ISO 7040-M20-N			12

(Informacinis matmuo)
Nenurodytos matmenų nuokrypis: H14, h14, ± IT14/2
Aštrias briaunas užapvalinti R 0.2 mm

Pjaunama lazeriu	Parašas ir data
	2021-02-24

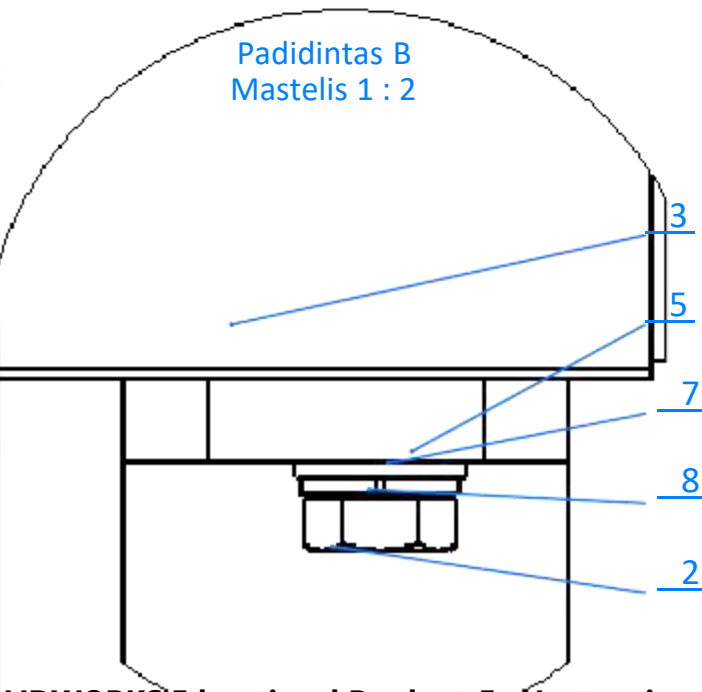

	Parašas	Data	OM.72.00.00.00.00.00.00.SB - 010		
			Plaktukinis malūnas OM.HM.700		
Parengė Tikrinio T. kontr.	S. Mikalauskas T. Teskevičius				Lapas 1 Lapų sk. 2
Formatas A3					Užsakymo vnt.: 1

(Informacinis matmuo)
 Nenurodytos matmenų nuokrypis: H14, h14, H14/2
 Aštrius briaunas užapvalinti R 0.2 mm

1.
2.
3.

Parašas ir data

Data
2021-02-24

Pjaunama lazeriu

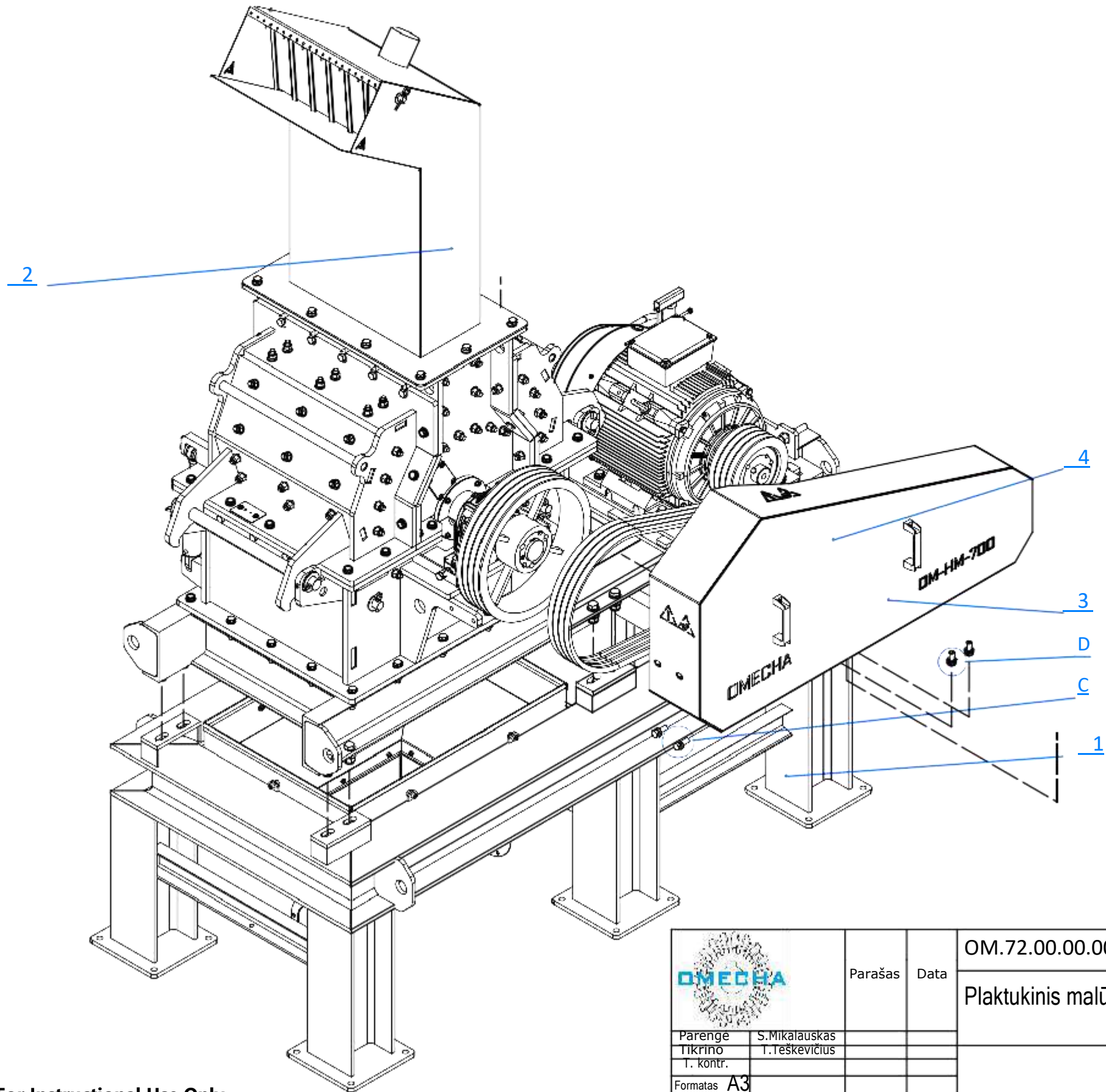

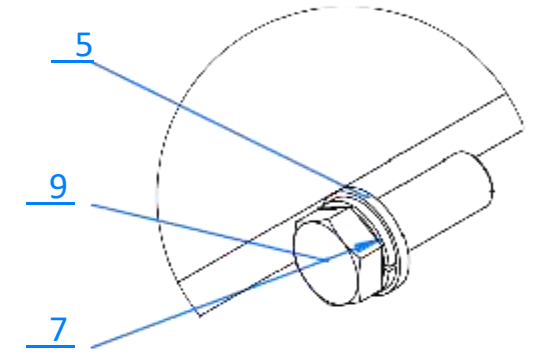

Padidintas C
Mastelis 1 : 2

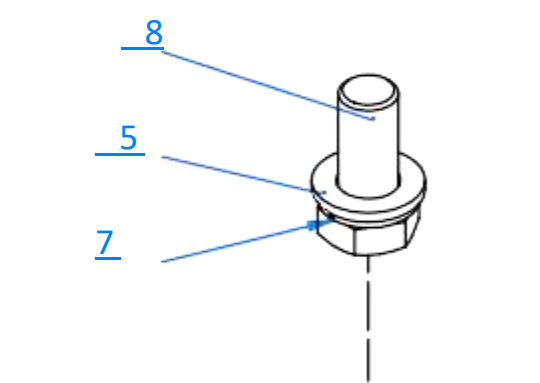

Padidintas D
Mastelis 1 : 2



	Parašas	Data	OM.72.00.00.00.00.00.00.SB - 010		
			Plaktukinis malūnas OM.HM.700		
Parengė Tikrinio T. kontr.	S.Mikalauškas T. Teškevičius				Lapų sk. 2
Formatas A3					Užsakymo vnt.: 1

POZ.	ŽYMĖJIMAS	KONFIG.	APRAŠYMAS	KIEKIS
1	OM.72.10.10.00.00.00.00.00.SB	010	Apatinis rėmas	1
2	OM.72.10.20.00.00.00.00.00.00.SB	010	Apatinis piltuvas	1
3	OM.72.10.30.00.00.00.00.00.00.00.SB	010	Žemutinis piltuvas	1
4	OM.72.10.00.00.00.00.00.00.00.00.1	010	Tarpinė b- 40, s-2	1
5	A2 5164 sandariklis Fotas	010	Sandariklis	2
6	A2 5164 sandariklis Fotas	020	Sandariklis	2
7	Washer DIN 125 - A 8.4			12
8	DIN 912 M8 X 20		Varžtas	12
9	DIN 912 M12 X 25		Varžtas	6

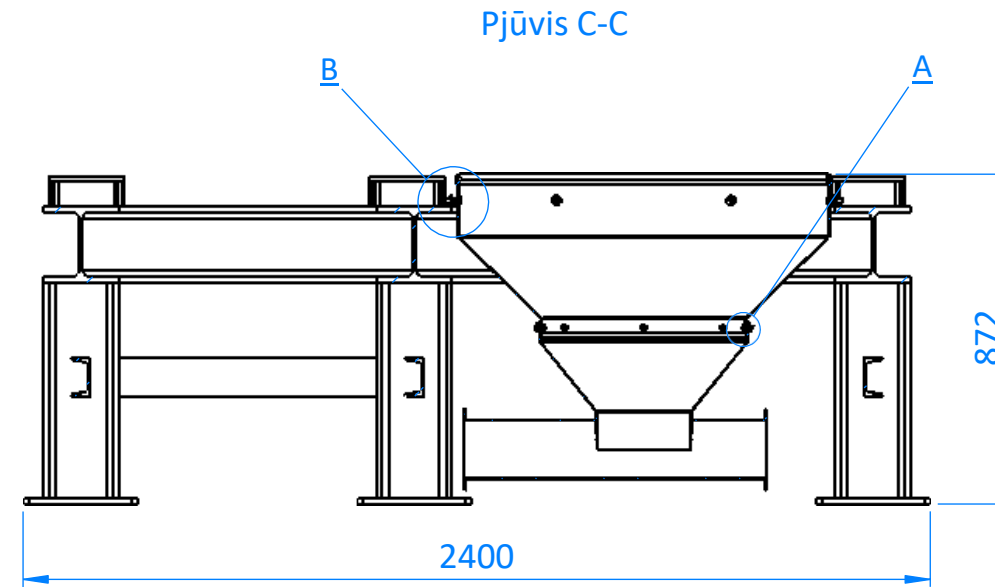
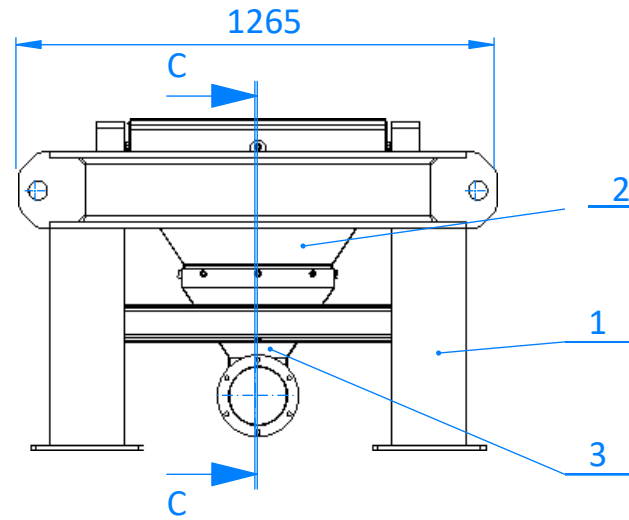

Padidintas A
Mastelis 1 : 2

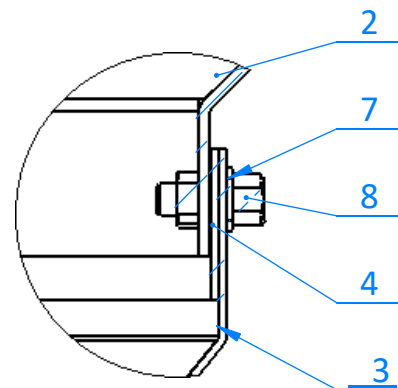

Padidintas B
Mastelis 1 : 3

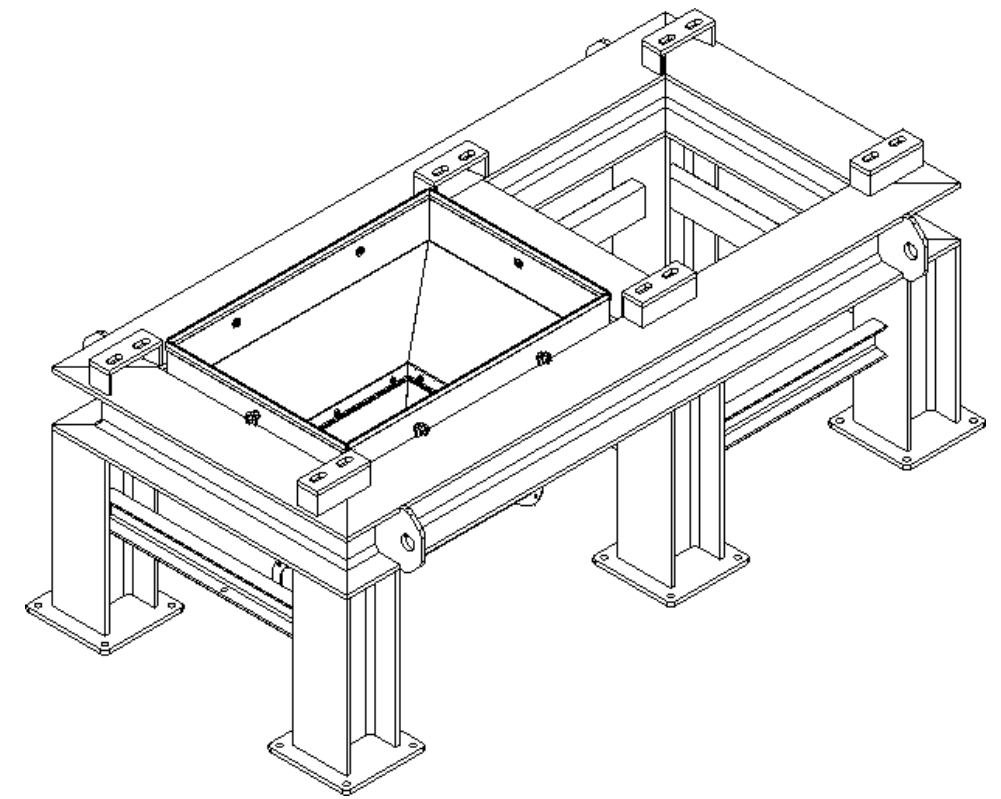
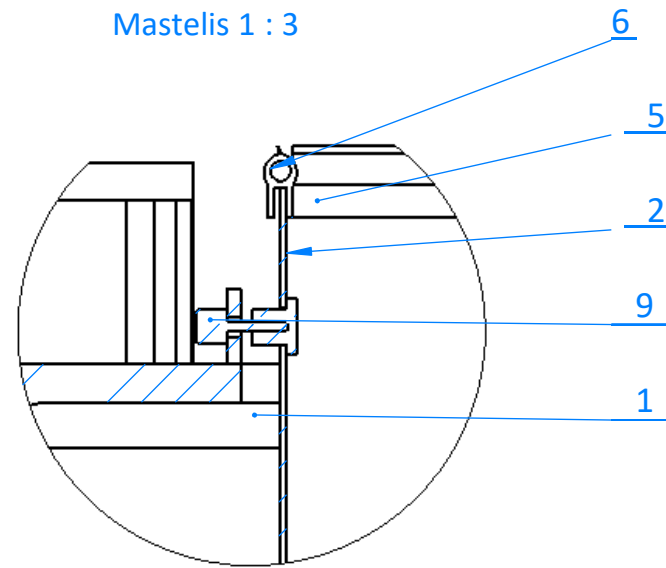

(Informacinis matmuo)
Nenurodytos matmenų nuokrypos: H14, h14, ±IT14/2
Aštrias briaunas užapvalinti R 0.2 mm

1.
2.
3.

Parašas ir data

Data
2021-02-24

Pjaunama lazeriu

OMECHA

Parašas
Data

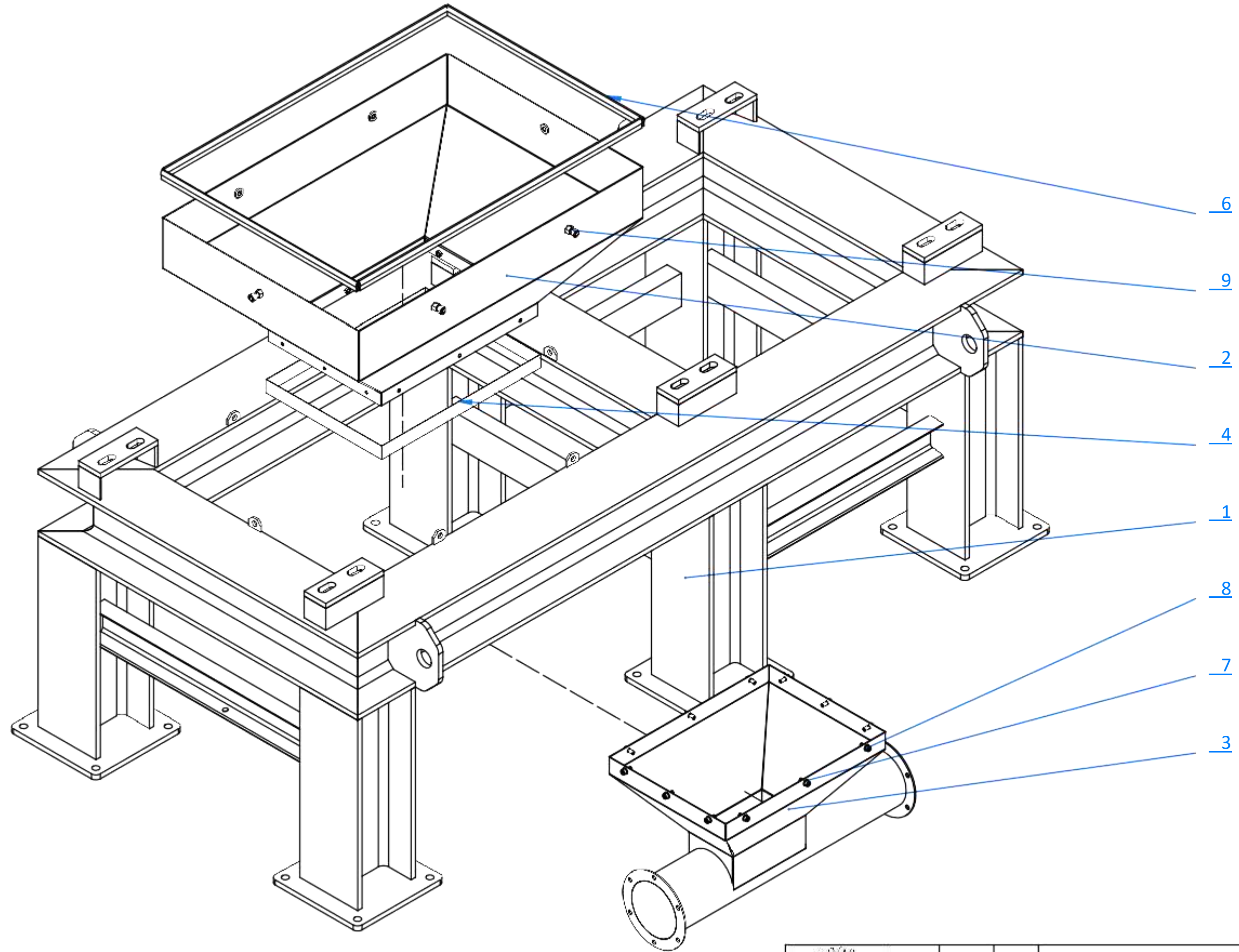

OM.72.10.00.00.00.00.00.00.SB - 010			
Žemutinis malūno rėmas		Masė 801.28	Mastelis 1:20
		Lapas 1	Lapų sk. 2
		Užsakymo vnt.: 1	



(Informacinis matmuo)
 Nenurodytos matmenų nuokrypos: H14, h14, H14/2
 Aštrūs briaunoms užapvalinti R 0.2 mm

1.
2.
3.

Pjaunama lazeriu	Parašas ir data
	2021-02-24

 Parengė S. Mikalauskas Tikrino T. Teskevičius T. kontr. Formatas A3	Parašas	Data	OM.72.10.00.00.00.00.00.SB - 010		 Mastelis 1:10 Lapų sk. 2
			Žemutinis malūno rėmas		
			Užsakymo vnt.: 1		

POZ.	ŽYMĖJIMAS	KONFIG.	APRAŠYMAS	KIEKIS
1	OM.72.20.20.10.00.00.000.SB	010	Apatinio korpuso surinkimas	1
2	OM.72.20.20.20.00.00.000.SB	010	Surinktas velenas	1
3	OM.72.20.20.30.00.00.000.SB	010	Vidurinis viršutinis korpusas	1
4	OM.72.20.20.40.00.00.000.SB	010	Viršutinio dangčio surinkimas	1
5	OM.72.20.20.40.00.00.000.SB	020	Viršutinio dangčio surinkimas	1
6	OM.72.20.20.50.00.00.000.SB	010	Hidraulinio cilindro atrama	2
7	OM.72.20.20.60.00.00.000.SB	010	Hidraulinio cilindro kaištis	4
8	OM.72.20.20.00.00.00.001	010	Strypas Ø40 x 650	2
9	OM.72.20.20.00.00.00.002	010	s_8	4
10	Washer DIN 125 - A 6.4	Washer DIN 125 - A 6.4		4
11	Washer DIN 125 - A 17	Washer DIN 125 - A 17		78
12	Washer DIN 125 - A 21	Washer DIN 125 - A 21		8
13	DIN 125 - B 41	Washer DIN 125 - B 41	Poveržlė	8
14	ISO 4017 M6 X 12	ISO 4017 - M6 x 12-N	Varžtas	4
15	ISO 4017 M16 X 35	ISO 4017 - M16 x 35-N	Varžtas	10
16	ISO 4017 M16 X 70	ISO 4017 - M16 x 70-N	Varžtas	34
17	ISO 4017 M20 X 100	ISO 4017 - M20 x 100-N	Varžtas	4
18	ISO 7040-M16	ISO 7040-M16-N	Veržlė su kapronu	34
19	ISO 7040-M20	ISO 7040-M20-N	Veržlė su kapronu	4
20	HMB2250200	010	Hidraulinis cilindras	2
21	TBS 500 SPC 4 3535	Default	Didysis diržinis skriemulys	1
22	3535 A 75	Default	Didžiojo diržinio skriemulio tvirtinimo įvorė	1
23	Din 11023	010		4
24	DIN 6885 20 X 12 X 90	Parallel key A20 x 12 x 90 DIN 6885	Pleištas	1

Data	Parašas ir data			
	Pak.	Lapas	Dokum. nr.	Parašas
	Parengė	S.Mikalauskas		
	Tikrino	T.Teškevičius		
	T. kontr.			

OM.72.20.20.00.00.00.000.SB		-	010	Masė	Mastelis
				2072.25	1:20
				Lapas	Lapų
				1	3
					

Plaktukinis malūnas

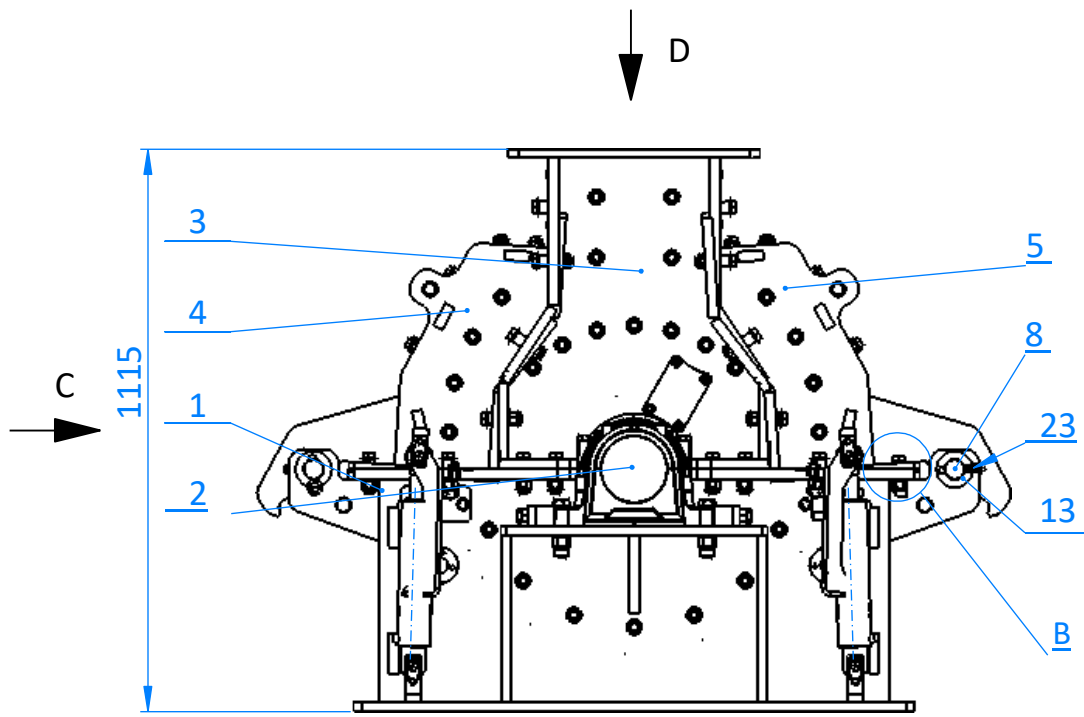

Vaizdas D

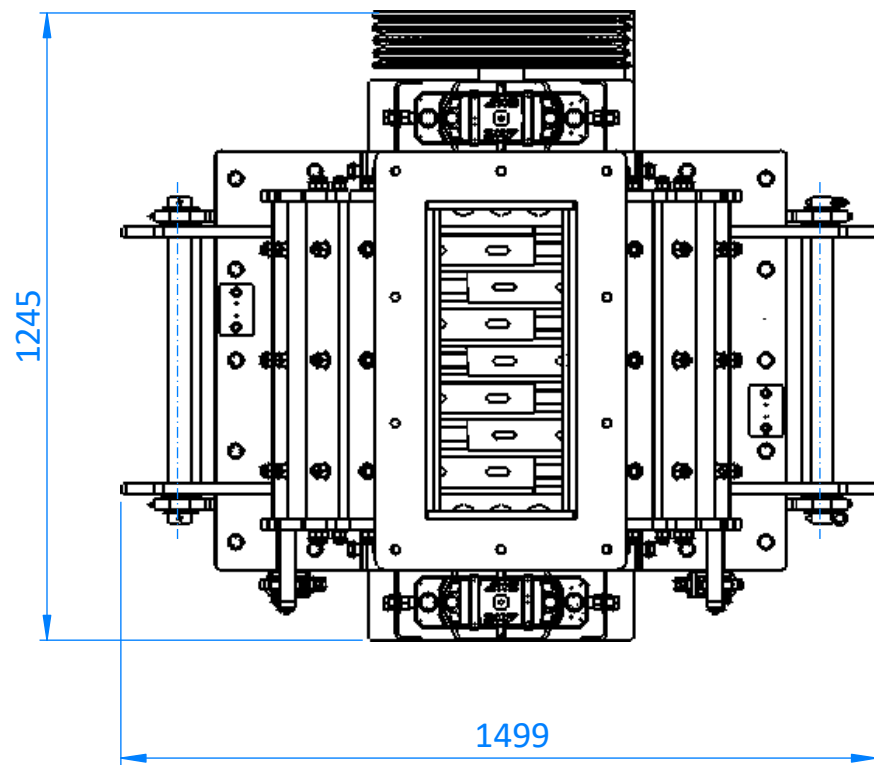

Vaizdas C

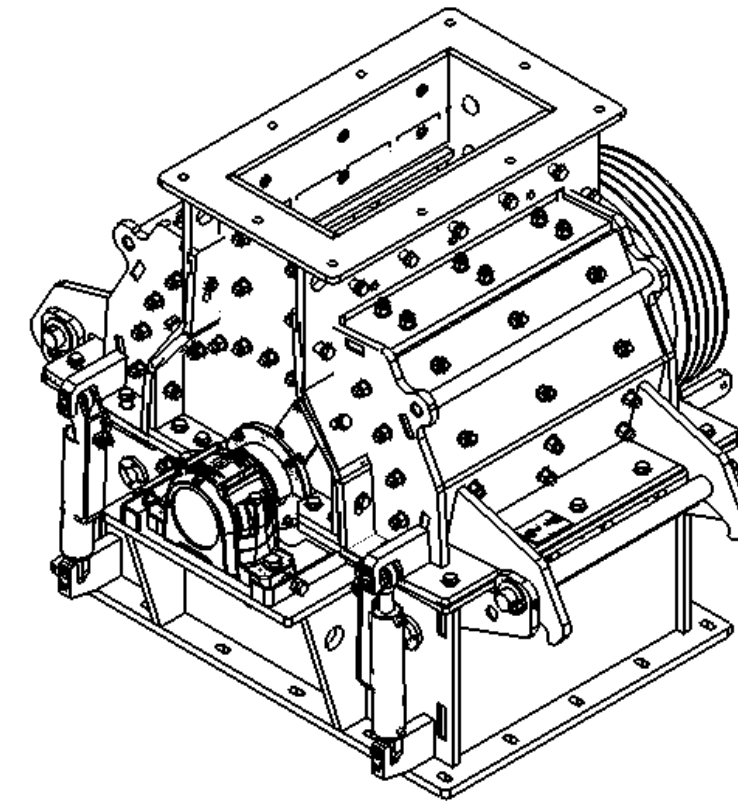
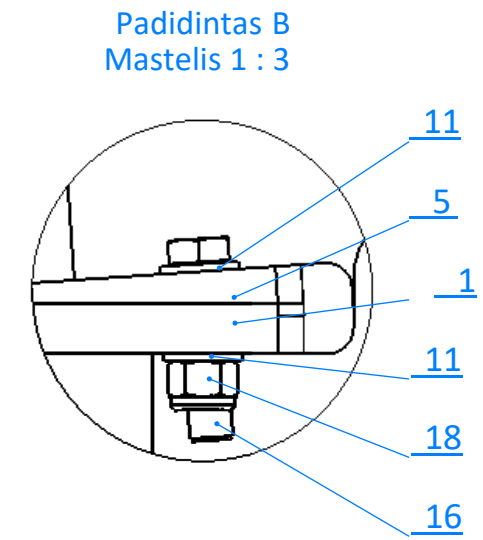
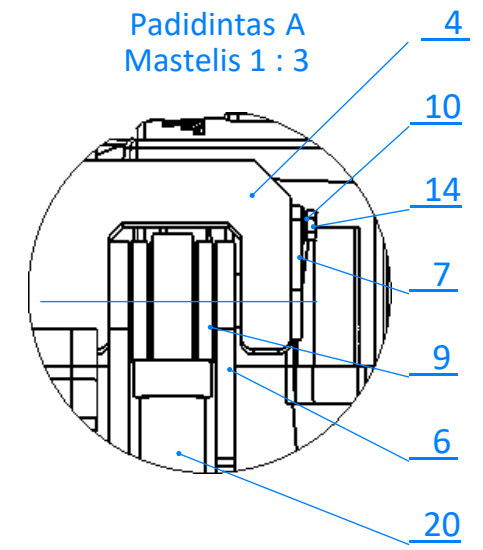
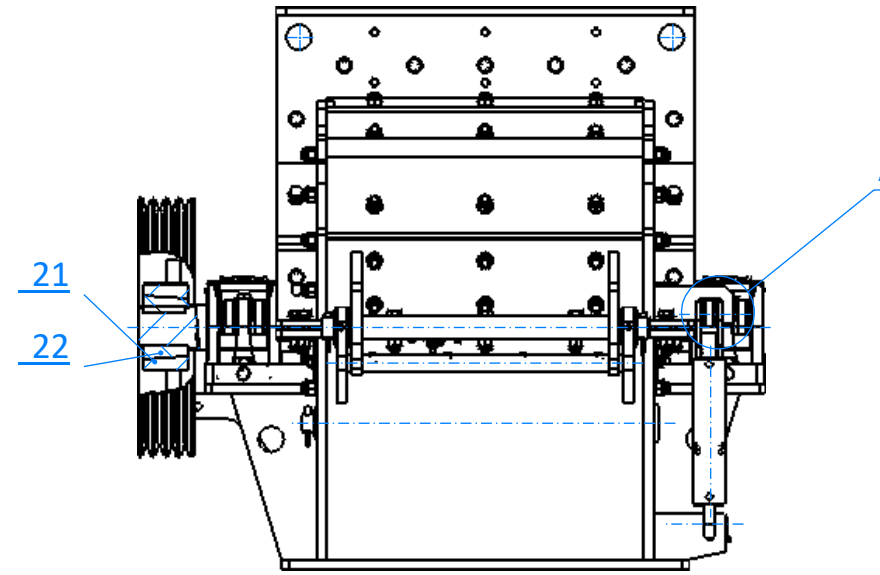

(Informacinis matmuo)
 Nenurodytos matmenų nuokrypis: H14, h14, fE14/2
 Aštrias briaunas užapvalinti R 0.2 mm

1.
 2.
 3.

Pjaunama lazeriu	Parašas ir data
	2021-02-23

	Parašas	Data	OM.72.20.20.00.00.00.00.SB - 010	
			Plaktukinis malūnas	
Parengė S. Mikalauskas			Masė	Mastelis
Tikrino T. Teškevičius			2072.25	1:15
T. kontr.			Lapas 2	Lapų sk. 3
Formatas A3			Užsakymo vnt.: 1	

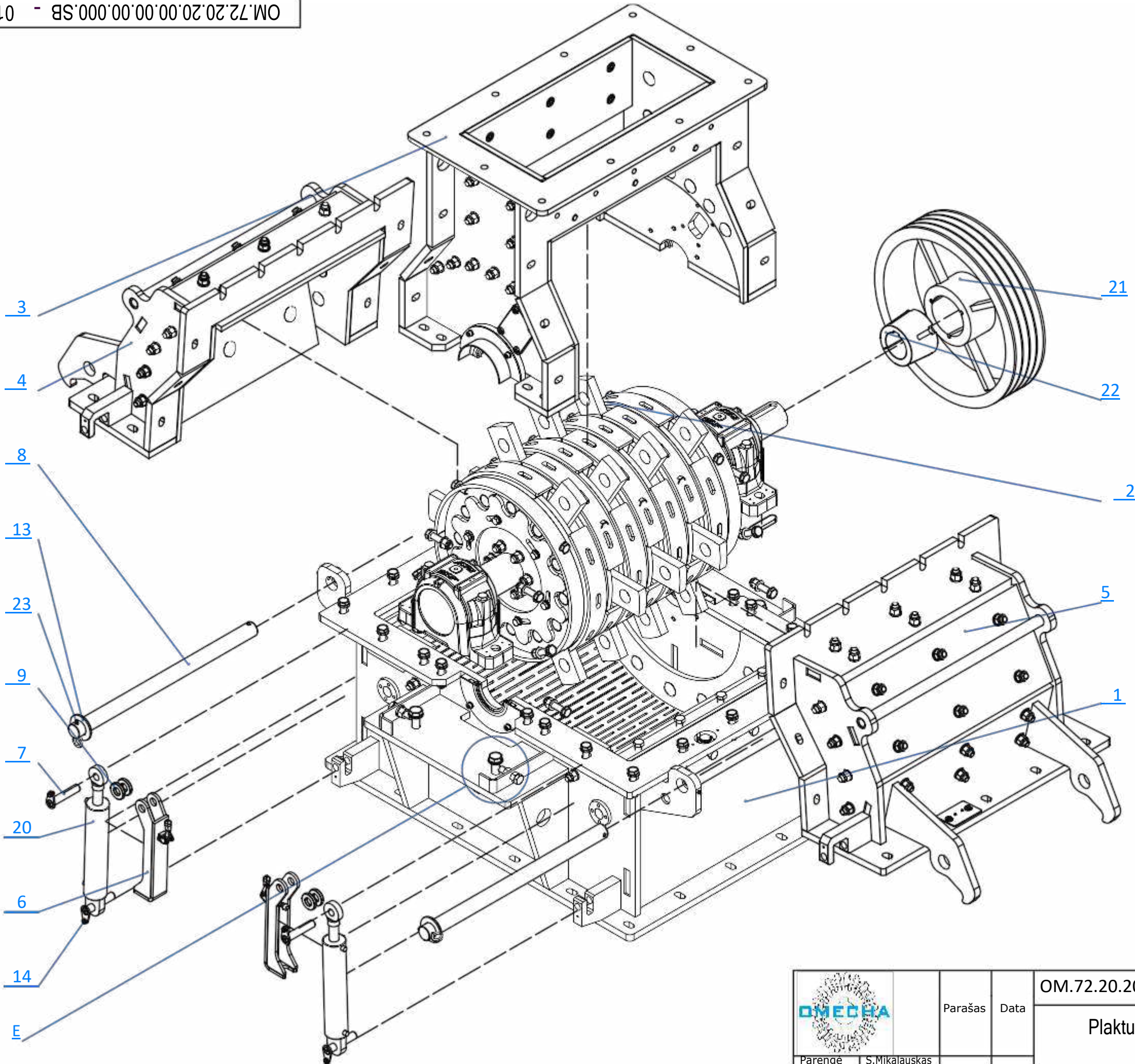

(Informacinis matmuo)
Nenurodytos matmenų nuokrypis: H14, h14, H14/2
Aštrias briaunas užapvalinti R 0.2 mm

1.
2.
3.

Pjaunama lazeriu	Data	Parašas ir data
	2021-02-23	

		Parašas	Data	OM.72.20.20.00.00.000.SB - 010	
				Plaktukinis malūnas	
Parengė	S.Mikalauskas			Masė	Mastelis
Tikrino	T.Teskevičius			2072.25	1:10
T. kontr.				Lapas 3	Lapų sk. 3
Formatas	A3			Užsakymo vnt.: 1	

POZ.	ŽYMĖJIMAS	KONFIG.	APRAŠYMAS	KIEKIS
1	OM.72.20.20.10.10.00.000.SB	010	Apatinio korpuso II suvirinimas	1
2	OM.72.20.20.10.20.00.000.SB	010	Malūno sietas	1
3	OM.72.20.20.10.30.00.000.SB	010	Kaištis sietui	2
4	OM.72.20.20.10.40.00.000.SB	010	Magnetinio daviklio apačia	2
5	OM.72.20.20.10.00.00.001	010	s_15	2
6	OM.72.20.20.10.00.00.002	010	HARDOX priešpeilis 30x80, L-670	2
7	OM.72.20.20.10.00.00.003	010	s_6	4
8	OM.72.20.20.10.00.00.004	010	Sandariklio laikymo pusmėnulis	2
9	OM.72.20.20.10.00.00.005	010	s_3	2
10	Washer DIN 9021 - 6.4	Washer DIN 9021 - 6.4		4
11	DIN 125 - Ø8.4	Washer DIN 125 - A 8.4	Poveržlė	4
12	DIN 125 - Ø13	Washer DIN 125 - A 13	Poveržlė	8
13	DIN 125 - Ø17	Washer DIN 125 - A 17	Poveržlė	22
14	DIN 125 - Ø31	Washer DIN 125 - A 31	Poveržlė	2
15	Spring washer DIN 128 - A6	Spring washer DIN 128 - A6		4
16	Spring washer DIN 128 - A8	Spring washer DIN 128 - A8		4
17	DIN 912 M8 x 16 --- 16N	DIN 912 M8 x 16 --- 16N		4
18	DIN 912 M10 X 30	DIN 912 M10 x 30 --- 30N	Varžtas	6
19	ISO 4017 M6 X 20	ISO 4017 - M6 x 20-N	Varžtas	4
20	ISO 4017 - M12 x 30-N	ISO 4017 - M12 x 30-N		8
21	ISO 4017 - M16 x 60-N	ISO 4017 - M16 x 60-N		4
22	ISO 4017 M16 X 90	ISO 4017 - M16 x 90-N	Varžtas	8
23	ISO 4034 - M16	ISO - 4034 - M16 - N	Veržlė	12
24	ISO 7040-M16	ISO 7040-M16-N	Veržlė su kapronu	14
25	DIN_71412_M8 x 0.75_9er_6kt	Default	Tepimo taškas	4
26	Din 11023	020	d_8, L-42	2
27	SKF SNL 524-620-90-tsnl	Default	Riebokšlis	2
28	DIN 603 M16 X 65	Default	Varžtas apvalia galva su kvadratinio koteliu	14
29	ISO 8676 - M16x1.5 x 35-N	ISO 8676 - M16x1.5 x 35-N		8

Parašas ir data

Data

2021-02-24

Pak. lapas Dokum. nr. Parašas Data

Parengė S.Mikalauskas
Tikrinio T.Teškevičius
T. kontr.

OM.72.20.20.10.00.00.000.SB - 010

Apatinio korpuso surinkimas

Masė Mastelis

569.13 1:10
Lapas Lapų

1 3



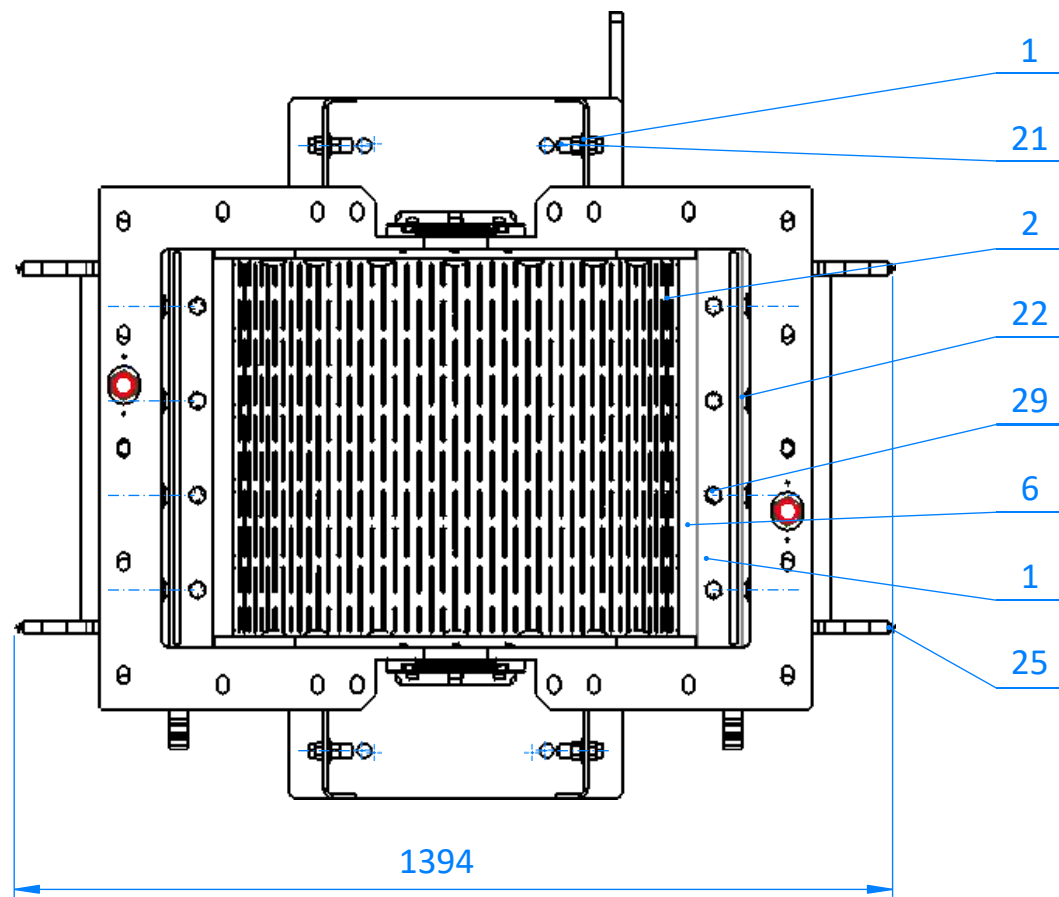
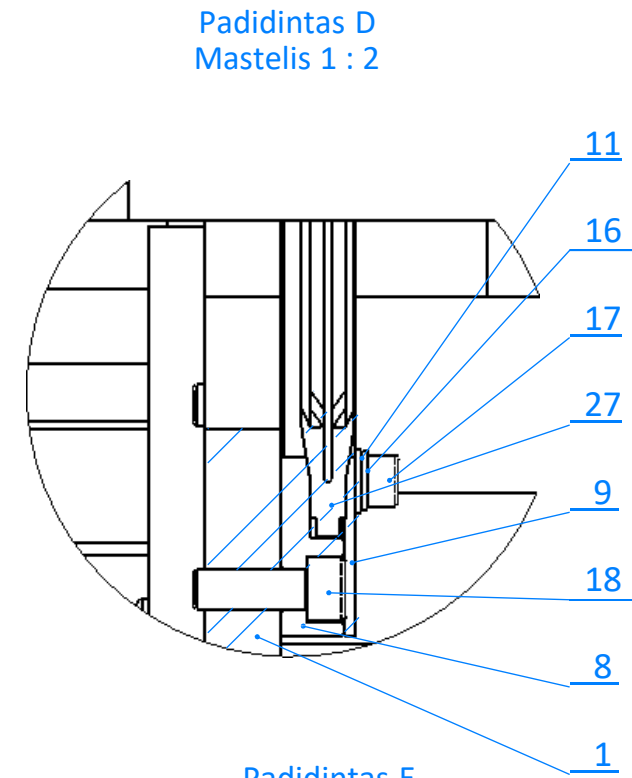
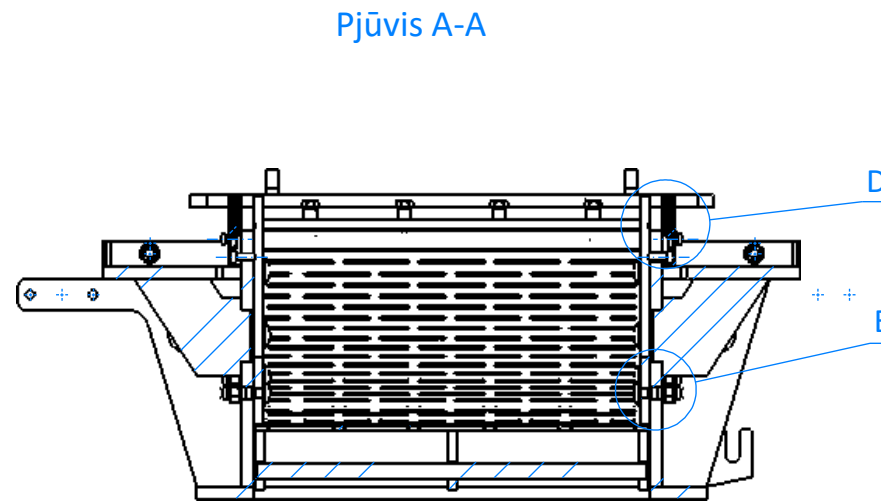
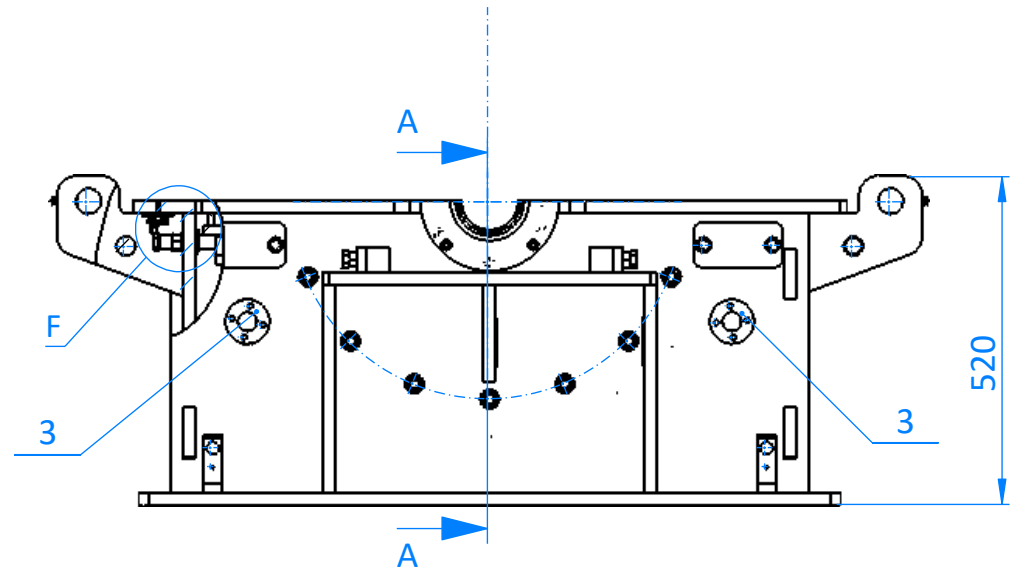

Vaizdas
MASTELIS (1 : 12)

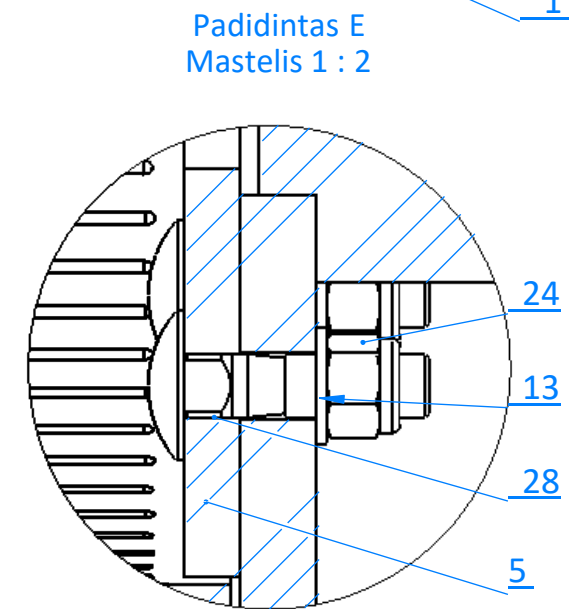
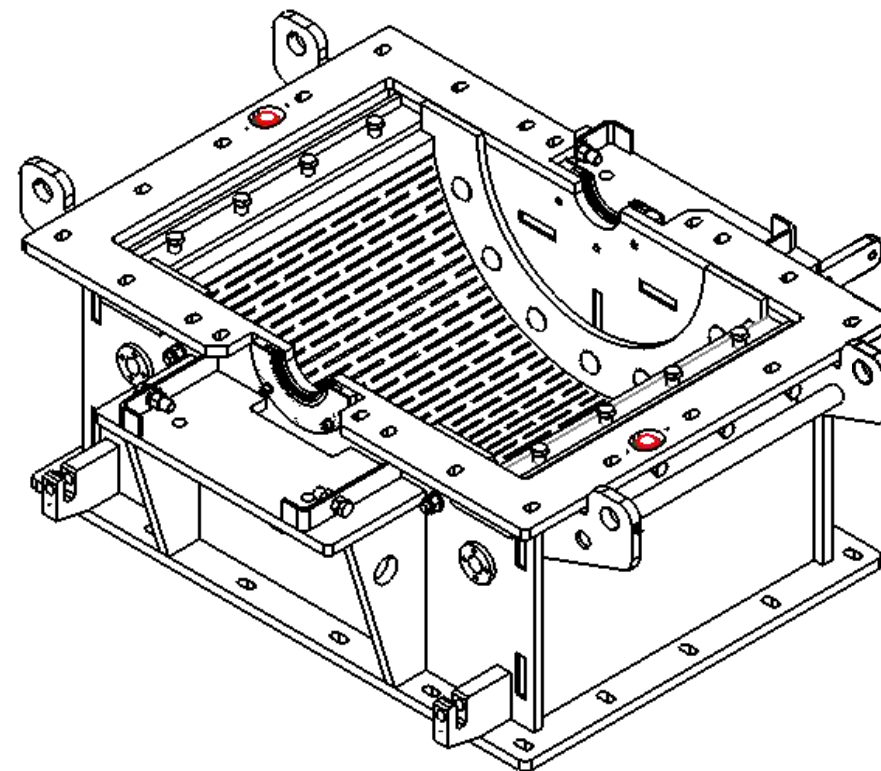

Padidintas F
Mastelis 1 : 2

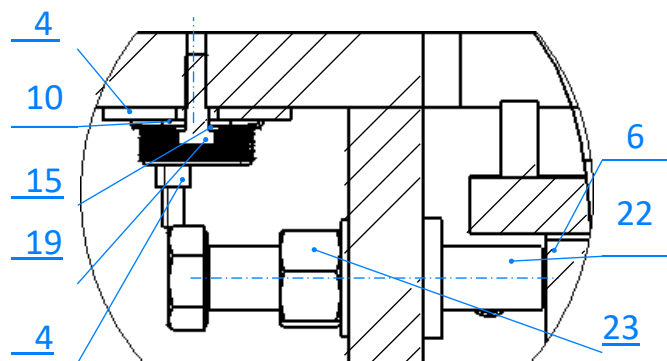

(Informacinis matmuo)
Nenurodytos matmenų nuokrypos: H14, h14, IT14/2
Aštrius briaunas užapvalinti R 0.2 mm

1.
2.
3.

Pjaunama lazeriu	Parašas ir data
	2021-02-24

	Parašas	Data	OM.72.20.20.10.00.00.00.SB - 010	
	Parengė S. Mikalauskas Tikrinio T. Teškevičius T. kontr. Formatas A3			

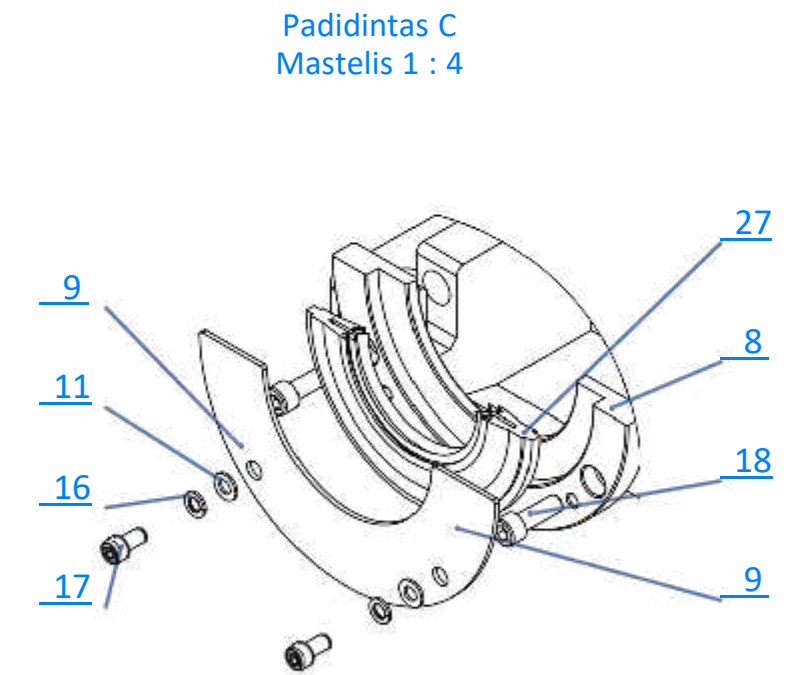
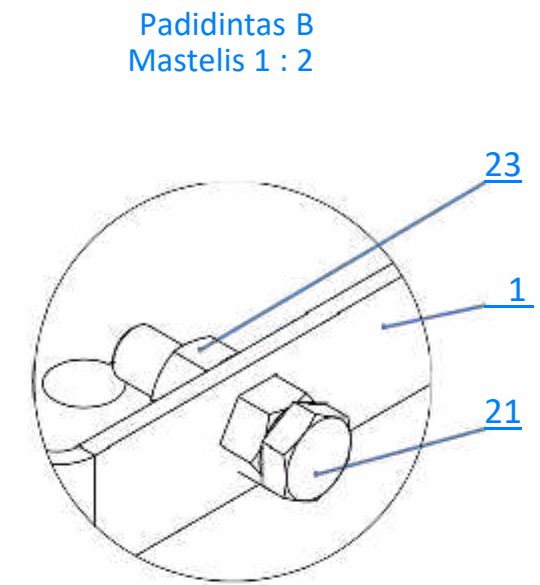
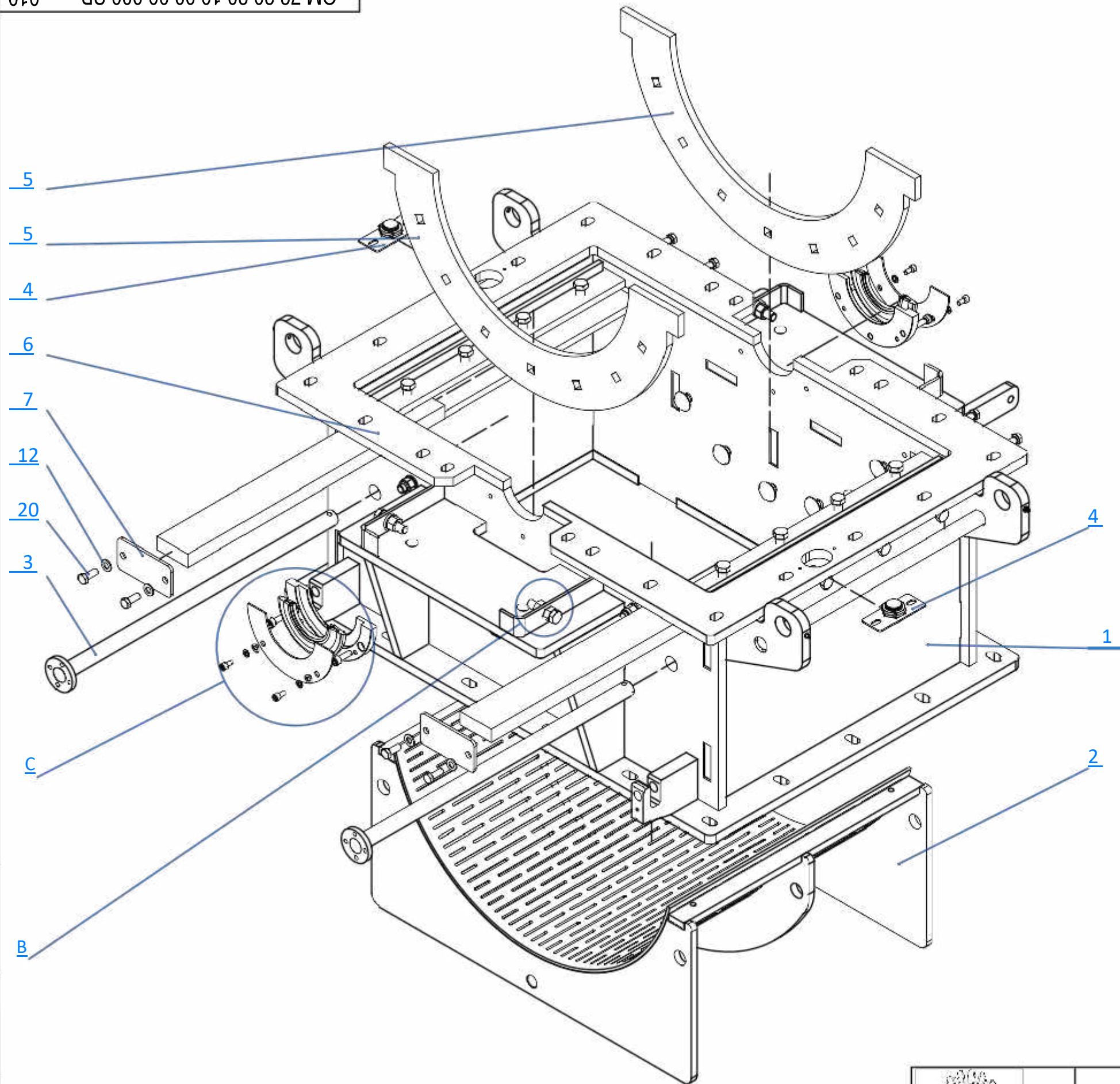

(Informacinis matmuo)
Nenurodytos matmenų nuokrypis: H14, h14, IT14/2
Aštrūs briaunus užapvalinti R 0.2 mm

1.
2.
3.

Pjaunama lazeriu	Parašas ir data
	2021-02-24

	Parašas	Data	OM.72.20.20.10.00.00.00.SB - 010	
			Apatinio korpuso surinkimas	
Parengė	S.Mikalaukas		Masė	Mastelis
Tikrinio	I. Teskevičius		569.13	1:8
I. kontr.			Lapas 3	Lapų sk. 3
Formatas	A3		Užsakymo vnt.: 1	

POZ.	ŽYMĖJIMAS	KONFIG.	MEDŽIAGA	APRAŠYMAS	KIEKIS
1	OM.108 10.000.000.000.SB	010		Filtro stovas	1
2	OM.108 20.000.000.000.SB	010		Oro filtras	1
3	OM.108 30.000.000.000.SB	010		Perėjimas su alkune	1
4	OM.108 40.000.000.000.SB	010		Perėjimas	1
5	OM.108 50.000.000.000.SB	010		Alkunė 90° d_150	1
6	OM.108 60.000.000.000.SB	010		Du ciklonai	1
7	OM.108 70.000.000.000.SB	010		Ciklono piltuvai	1
8	OM.108 80.000.000.000.SB	010		Ciklono trišakis	1
9	OM.108 90.000.000.000.SB	010		Magneto stovas	1
10	OM.108 100.000.000.000.SB	010		Alkunė 90°	1
11	OM.108 110.000.000.000.SB	010		Alkunė 60°	1
12	OM.108 120.000.000.000.SB	010		Pereiga nuo filtro	1
13	OM.108 130.000.000.000.SB	010		Stalas	1
14	OM.108 140.000.000.000.SB	010		Lakštinis stovas	1
15	OM.108 150.000.000.000.SB	010		Statinės dangtis	1
16	OM.108 160.000.000.000.SB	010		Vedinimo sistema	1
17	OM.108 00.000.000.001	010	NEOPRENE	Tarpinė d_3	1
18	OM.108 00.000.000.002	020	NEOPRENE	Guminė tarpinė s_3	2
19	OM.108 00.000.000.002	010	NEOPRENE	Guminė tarpinė s_3	2
20	OM.108 00.000.000.003	010	NEOPRENE	Guminė tarpinė s_3	6
21	OM.108 00.000.000.004	010	NEOPRENE	Guminė tarpinė s_3	1
22	OM.108 00.000.000.005	010	NEOPRENE	Guminė tarpinė s_3	2
23	OM.108 00.000.000.006	010	NEOPRENE	Gofra Vul-FlexM-254, L-445 Sileta	1
24	SM 25-2R DN 200	Default			1
25	Hose Clamp hard d_250	Default	1.0037 (S235JR)	Sąvaržą d_250	2
26	Filtras	010	1.0037 (S235JR)	Filtras	1
27	Statinė su palete	Viena statinė			2
28	OM.72.00.00.00.00.00.000.SB	010	1.0037 (S235JR)		1
29	DIN 125 - Ø10.5	Washer DIN 125 - A 10.5		Poveržlė	160
30	ISO 4034 - M10	ISO - 4034 - M10 - N		Veržlė	80
31	ISO 4017 - M10 x 35-N	ISO 4017 - M10 x 35-N			81
32	DIN 125 - Ø17	Washer DIN 125 - A 17		Poveržlė	32
33	ISO 4017 - M16 x 45-N	ISO 4017 - M16 x 45-N			16
34	ISO 4034 - M16	ISO - 4034 - M16 - N		Veržlė	16

Parašas ir data

Data	2021-06-22	Pak. lapas	Dokum. nr.	Parašas	Data
		Parėngė	V. Dabkevičius		
		Tikrina	T. Teškevičius		
		T. kontr.			

OM.108 00.000.000.000.SB

- 010

Masė	Mastelis
8175.94	1:35
Lapas	Lapy
1	3

Malūno vedinimo sistema



POZ.	ZYVĖJIMAS	KDZVFG.	MEDŽIAGA	APVAŠVINMAS	KIEMS
1	Ortakis 315	010	Galvanized Steel	OS3-315 L-400	1
2	Ortakis 315	020	Galvanized Steel	OS3-315 L-3000	1
3	Ortakis 315	030	Galvanized Steel	OS3-315 L-100	1
4	Ortakis 200	010	Galvanized Steel	OS3-200, L-1000	1
5	Ortakis 200	020	Galvanized Steel	OS3-200, L-200	1
6	Ortakis 200	030	Galvanized Steel	OS3-200, L-100	2
7	Ortakio alkūnė d. 315	010	Galvanized Steel	AT-90-315	2
8	Ortakio alkūnė d. 200	020	Galvanized Steel	AT-90-200	1
9	Trisakis	010	Galvanized Steel	Trisakis TRT-45-315-200	1
10	Trisakis	020	Galvanized Steel	Trisakis TRT-45-200-100	1
11	Aprašai perėiga	010	Galvanized Steel	Perėiga PCT-350-315	1
12	Aprašai perėiga	020	Galvanized Steel	Perėiga PCT-315-200	1
13	Perėilimas	020	Galvanized Steel	SMF-300X300-200-300-1	1
14	Aprašai perėiga presuota	010	Galvanized Steel	PCTp-160-100	1
15	Movra šoninė	MI-355	Galvanized Steel	MI-355	1
16	Uždarymo silindras	d. 200	Galvanized Steel		1
17	Movra šoninė	MI-315	Galvanized Steel	MI-315	1

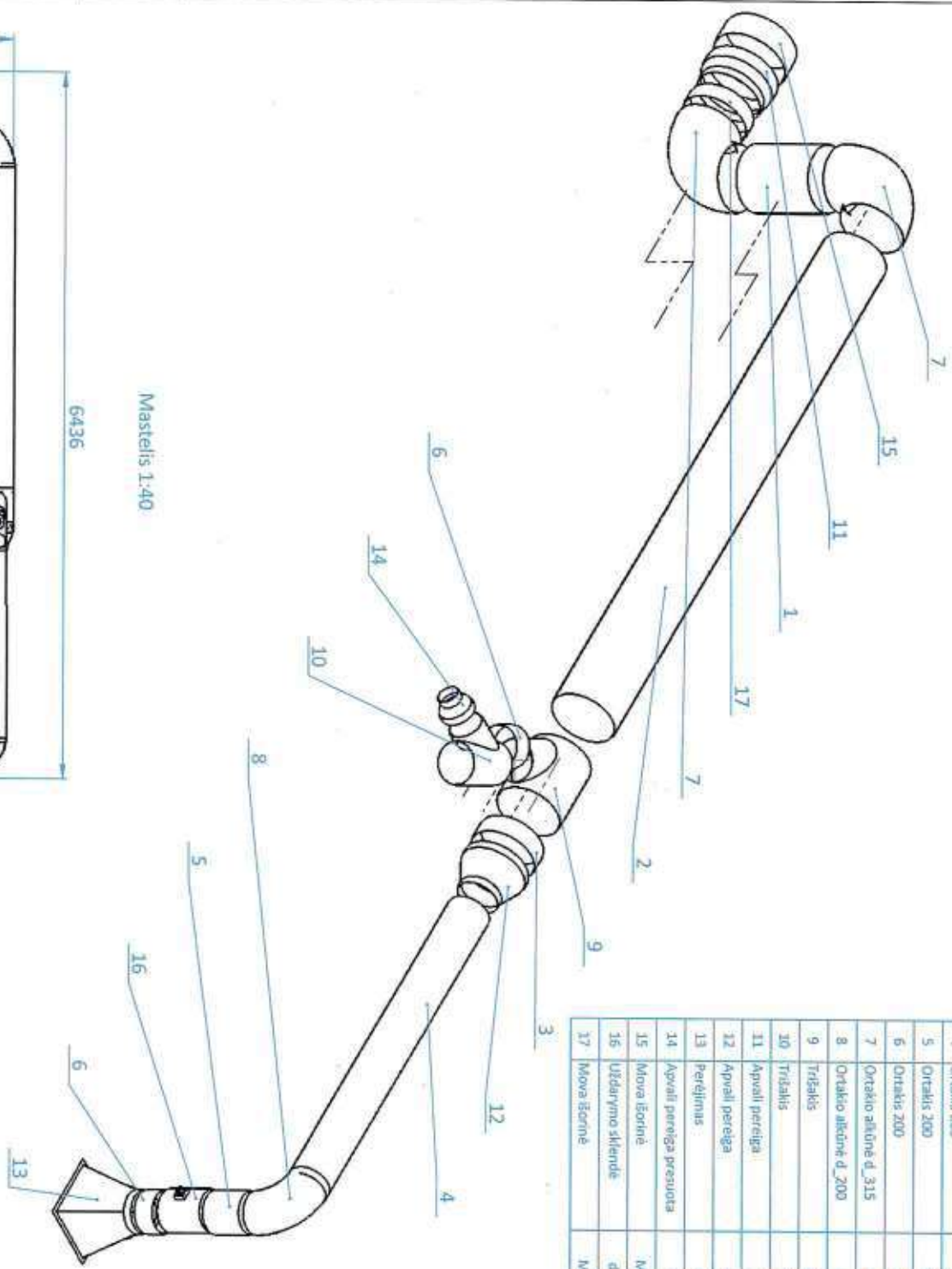

1. (Informacinis matmuo)
 2. Nenurodytos matmenų nuokrypis: H14, h14, ±IT14/2
 3. Atširas brėžimas užapvalinti 0,2 x 45° mm

Pjaunama lazeriu	Data	Parošos ir data
	2021-09-24	

Parošos Data

OM.108.160.000.000.SB - 010

Vedimo sistema

Uždarymo vntl.: 1

Lapai sk. 1

39.72

Mastelis 1:20

Pjaunama lazeriu	Paviršiaus išbaigimas	1.	[Informacinis matmuo] Nesurodytos matmenų nuokrypis: ±14, ±14, ±IT14/2 Aštrūs briaunai utapvalinti 0.2 x 45° mm
	UAB OMECHA	2.	
		3.	

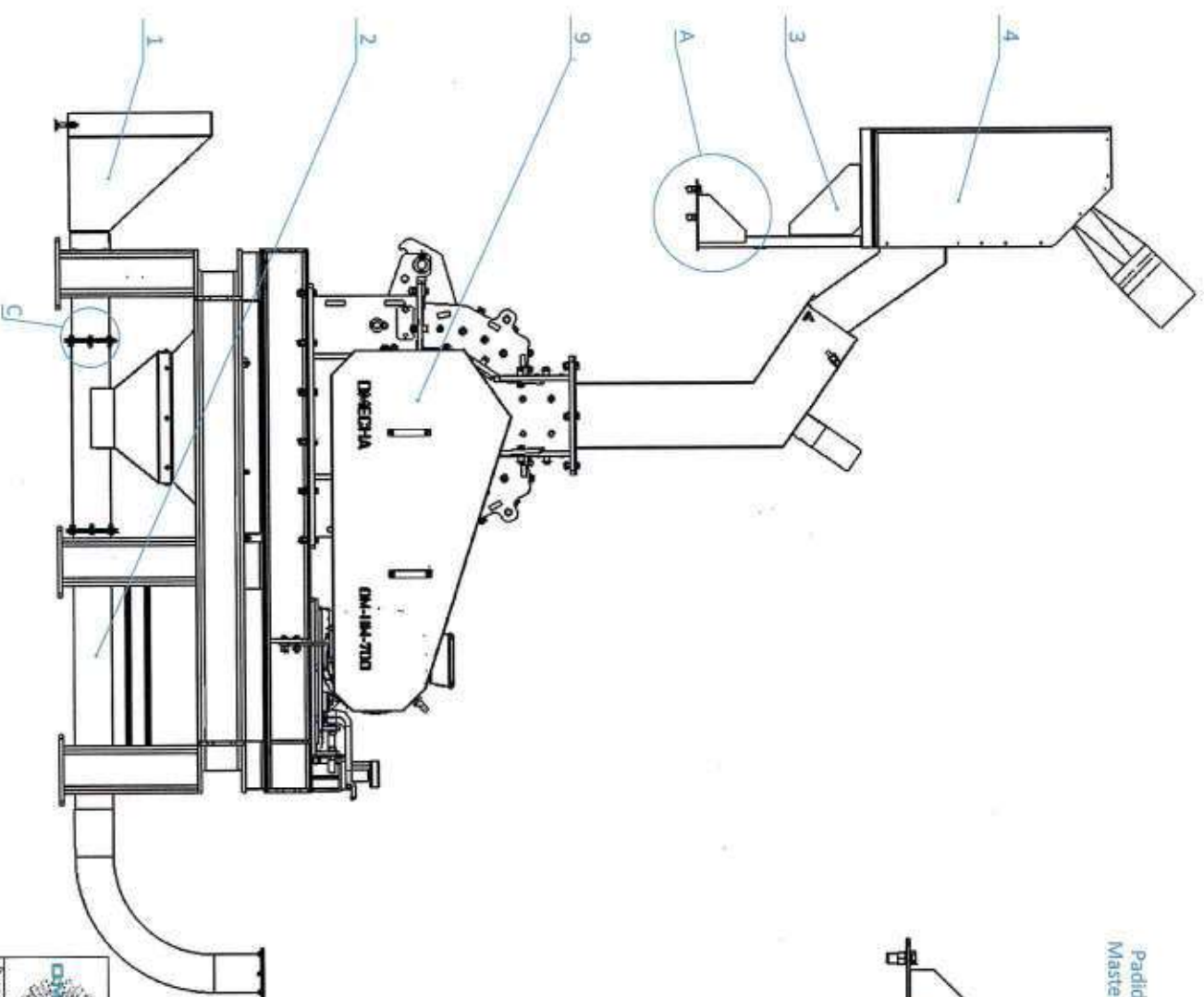

Padidintas A
Mastelis 1 : 10

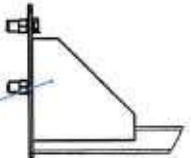
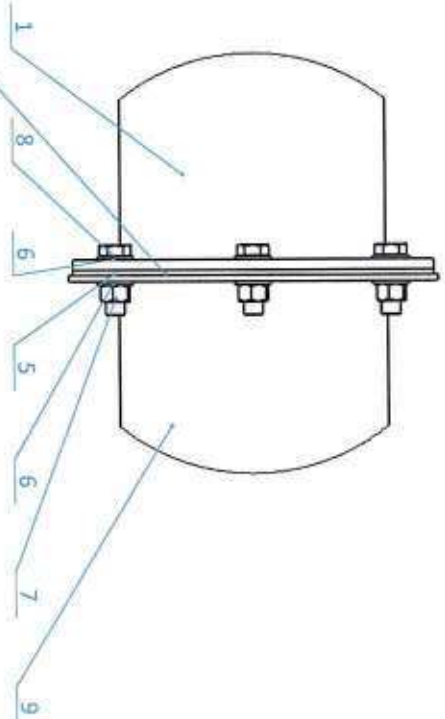

Table must be anchored firmly to the platform with provided holes.

Padidintas C
Mastelis 1 : 3



All of the pipe connections points must have a rubber seal between them.

POZ.	ZYVAVIMAS	APRAŠYMAS	KIEKIS
1	OM.108.20.000.000.000.SB	Orų filtrai	1
2	OM.108.30.000.000.000.SB	Perėjimai su aukure	1
3	OM.108.130.000.000.000.SB	Stalai	1
4	OM.108.140.000.000.000.SB	Lakštinis stovas	1
5	OM.108.00.000.000.003	Guminių tarpinė s_3	3
6	DIN 325 - Ø10.5	Poveržlė	30
7	ISO 4034 - M10	Veržlė	18
8	ISO 4017 - M10 x 35-N		12
9	OM.72.00.00.000.00.000.000.SB		1

		Paviršius	Dešis	OM.108.00.000.000.000.SB Maitino Prijungimas prie sistemos Maitino vedinimo sistema	Mošis 3668.32 Lapas 1 Lopy sk. 3	Užsakymo vnt.: 1
Parengė: V. Dabkevičius T. Koriš Formas: A3	T. Koriš T. Koriš					

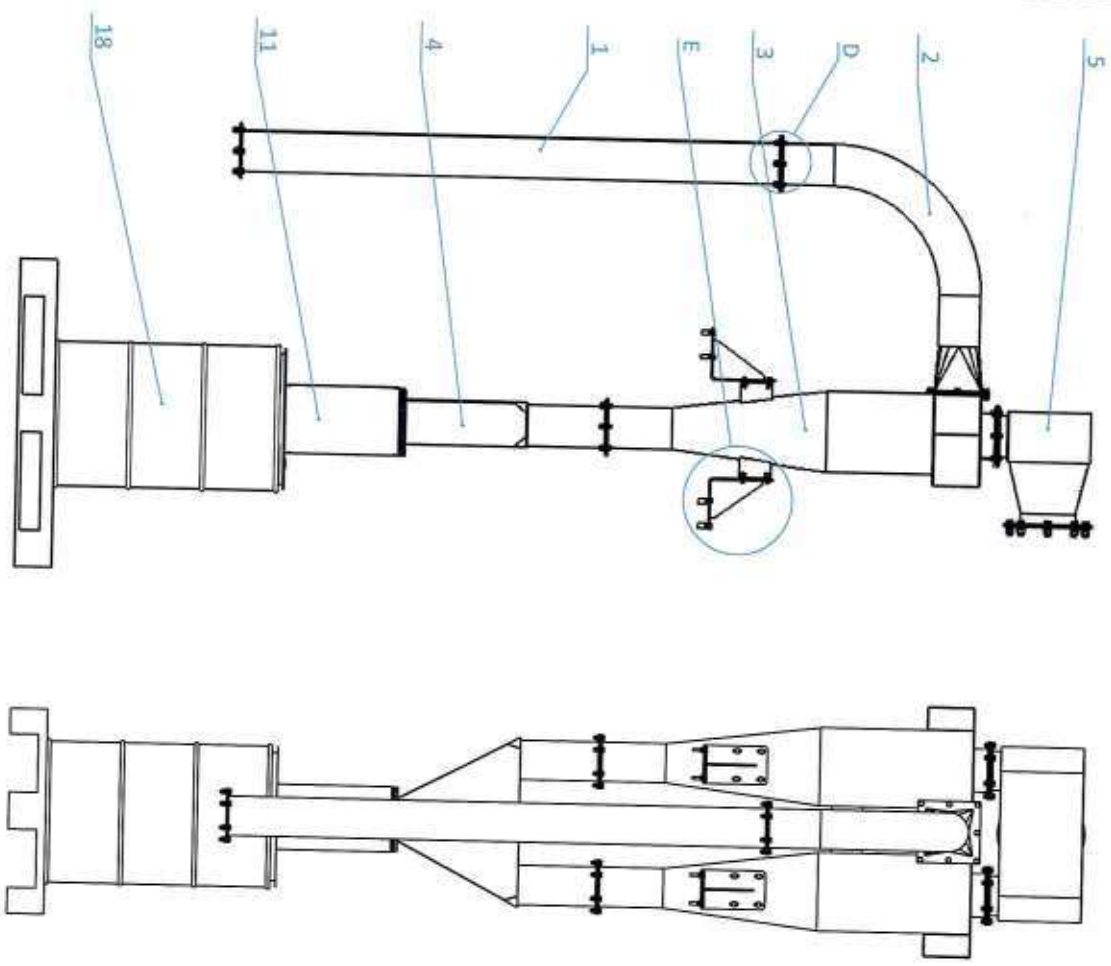

POZ.	ZYVENIMAS	APVAZAVIMAS	KIEKIS
1	OM.108.00.000.000.000.SB	Perėjimas	1
2	OM.108.50.000.000.000.SB	Aukštis 90° d. 150	1
3	OM.108.60.000.000.000.SB	Du cilionai	1
4	OM.108.70.000.000.000.SB	Ciklono piltava	1
5	OM.108.80.000.000.000.SB	Ciklono trėšakis	1
6	OM.108.150.000.000.000.SB	Statinės dangtis	1
7	OM.108.00.000.000.002	Gumtinė tarpinė s. 3	1
8	OM.108.00.000.000.003	Gumtinė tarpinė s. 3	4
9	OM.108.00.000.000.004	Gumtinė tarpinė s. 3	1
10	OM.108.00.000.000.005	Gumtinė tarpinė s. 3	2
11	OM.108.00.000.000.006	Gofra VUL-FlexM-254, L-445 Silėta	1
12	DIN 125 - Ø10.5	Poveržle	88
13	ISO 4034 - M10	Varžtė	44
14	ISO 4017 - M10 x 35-N		45
15	DIN 125 - Ø17	Poveržle	16
16	ISO 4017 - M15 x 45-N		8
17	ISO 4034 - M16	Varžtė	8
18	Steelinė su paliete		1
19	Hoop Clamp hard Ø. 250	Svaržtė Ø. 250	2

Padidintas D Mastelis 1 : 5

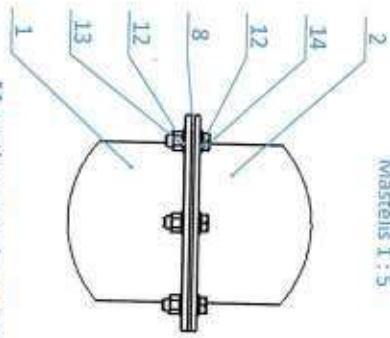

Padidintas E Mastelis 1 : 8



Mounting must be welded at the spot, according to platform position.

Mounting plates must be anchored to the platform.

All of the pipe connections points must have a rubber seal between them. Seals must be chosen by the flange.

1. (Informacinis matmuo)
2. Nenurodytos matmenų nuokrypis: H14, h14, ±IT14/2
3. Aštrūs briaunai užapvalinti 0,2 x 45° mm

Pjaunama lazeriu	Paviršiaus išbaigimas
	UAB OMECHA

		Pordis:	Data:
Paveržtė	V. Dabickienė		2023-12-29
Varžtas	T. Raškevicius		
Formalis:	A3		
OM.108.00.000.000.000.SB			
Ciklono surinkimas Malūno vedimo sistema		Kėlis 1870,98	Modulis 1:20
		Lapais: 2	Lapų sk.: 3
		Užsakymo vnt.: 1	

Pjaunama lazeriu	Paviršiaus išbaigimas
	UAB OMECHA

1.
2.
3.
(Informacinis matavimas)
Nenurodytos matmenų nuokrypis: H14, h14, ±IT14/2
Aštrūs brūkšniai užapvalinti 0.2 x 45° mm

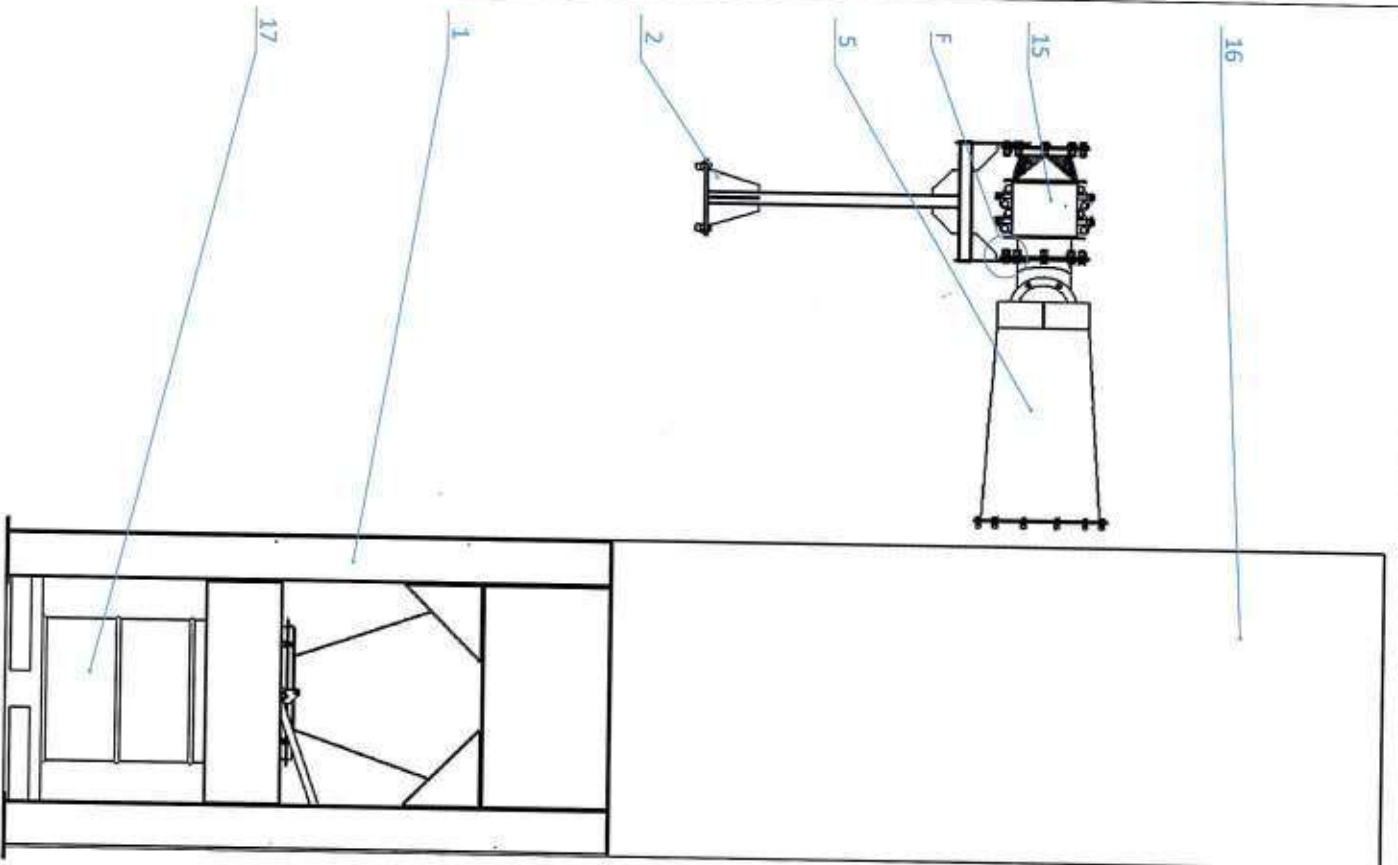

Padidintas F
Mastelis 1 : 3

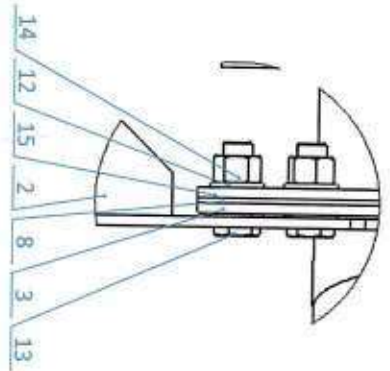

POS	ZYMEIMAS	APRAŠYMAS	KIEKIS
1	OM.108.10.000.000.000.SB	Filtru stovas	1
2	OM.108.90.000.000.000.SB	Magnetu stovas	1
3	OM.108.100.000.000.000.SB	Alkūnė 90°	1
4	OM.108.110.000.000.000.SB	Alkūnė 60°	1
5	OM.108.120.000.000.000.SB	Pereiga nuo filtro	1
6	OM.108.00.000.000.001	Tarpinė d_3	1
7	OM.108.00.000.000.002	Guminė tarpinė s_3	2
8	OM.108.00.000.000.002	Guminė tarpinė s_3	2
9	DIN 125 - Ø10,5	Poveržlė	48
10	ISO 4034 - M10	Veržlė	24
11	ISO 4017 - M10 x 35-N		24
12	DIN 125 - Ø17	Poveržlė	32
13	ISO 4017 - M16 x 45-N		16
14	ISO 4034 - M16	Veržlė	16
15	SM 25-2R DN 200		1
16	Filtrai	Filtrai	1
17	Stabinė su paleve		1

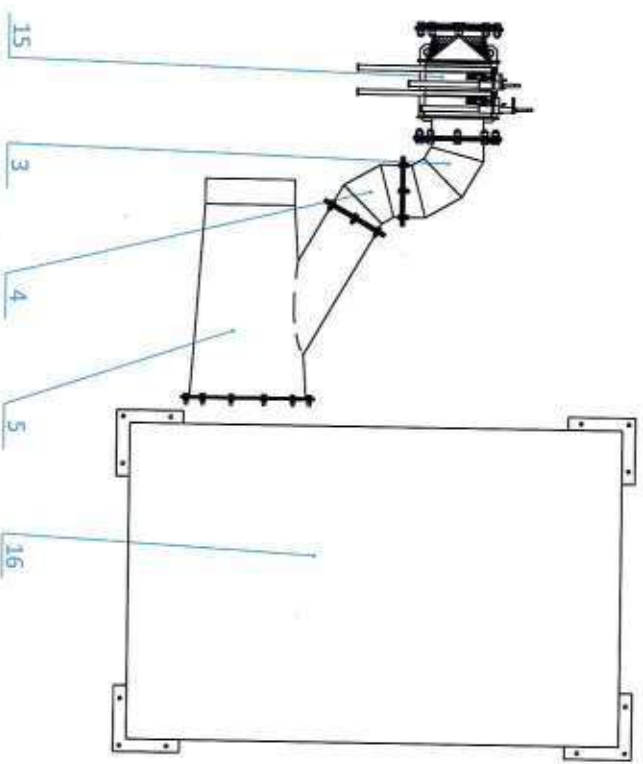

	Patalpas Doko	OM.108.00.000.000.000.SB	Modelis 2609.80		Mastelis 1:20
Potencinė filtrai 1. kortelė formata A3	2609.80 2609.80	Filtru su magnetu surinkimas Matavimo vedimo sistema	Uždėkymo vnt.: 1		

magnetix

USER MANUAL

Version: SM-2020-04
User Manual No.: M 21147-1

MAGNETIC SEPARATOR SM

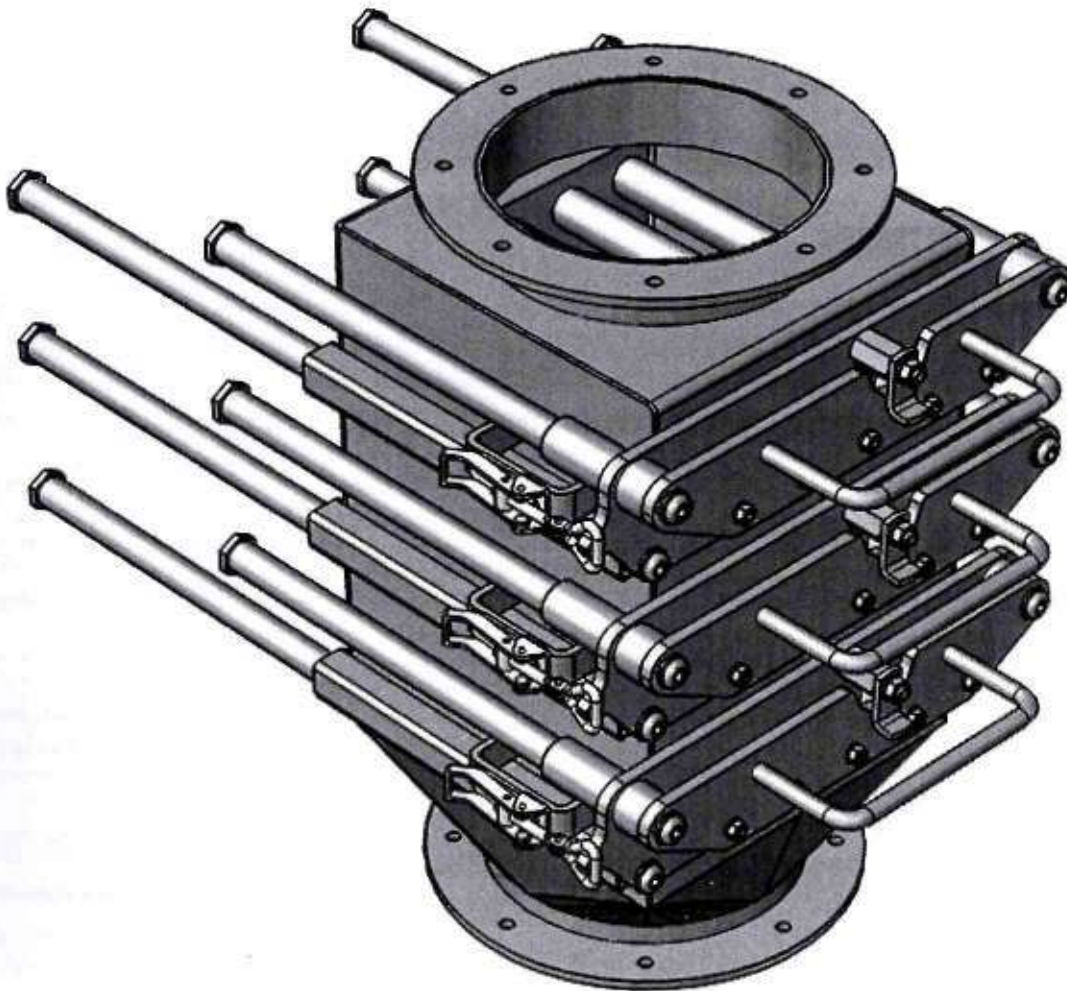

Table of Contents

1. INTRODUCTION	3
1.1 BASIC CONDITIONS AND GUIDELINES	3
2. SAFETY INSTRUCTIONS	4
2.1 WARNINGS AND SYMBOLS	4
2.2 SIGNS OF DEFECTIVE SEPARATOR OPERATION	4
2.3 HAZARDS IN MAGNETIC FIELD	5
3. APPLICATION AND INTENDED USE	6
4. TECHNICAL DESCRIPTION	7
4.1 MACHINE DESIGN	7
4.2 PRINCIPLE OF OPERATION	8
4.3 OPERATING CONDITIONS	8
5. ASSEMBLY INSTRUCTIONS	10
6. USER MANUAL	11
6.1 OPERATION	11
6.2 CLEANING	12
7. PACKAGING, TRANSPORT, AND STORAGE	14
7.1 TRANSPORT PACKAGING	14
7.2 STORAGE	14
7.3 TRANSPORT	14
8. MAINTENANCE AND LUBRICATION INSTRUCTIONS	16
8.1 MACHINE MAINTENANCE	16
8.2 LUBRICATION	16
8.3 INSPECTIONS	17
9. TECHNICAL SERVICE	17
10. TECHNICAL DATA SHEET OF THE DEVICE	18
10.1 DIMENSIONS OF THE DEVICE	18
10.2 TECHNICAL DATA	19
10.3 SPARE AND FAST-WEARING PARTS	20

1. INTRODUCTION

The manufacturer of the separator:

Magnetix sp. z o.o.
ul. Poznańska 9, Cierpice
87-103 Toruń



Read the instructions supplied with the separator before you start up the separator!



In case of any doubts concerning the contents of the Manual and the use of the separator itself, please contact the manufacturer's service.

1.1 BASIC CONDITIONS AND GUIDELINES

- Get to know the contents of the Manual in detail.
- Following the guidelines included in this Manual.
- Keep this manual close to the separator throughout its service life.
- The user is obliged to make the manual available to the operating personnel during the installation, operation and maintenance of the separator.
- The User is obliged to ensure that the operator reads the Manual and observes the safety rules it contains.
- The user is obliged to ensure that the operator complies with accident prevention and occupational health and safety regulations.
- Any activities related to: **transport, storage, assembly, installation, connection, and commissioning and maintenance** may only be performed by persons with appropriate permissions.



The separator is intended exclusively for the work described in the Manual. Using the separator for any purpose other than the intended use shall be considered an improper use, contrary to the intended use.



Any unauthorised changes or modifications made to the separator without the manufacturer's consent - disassembly or replacement of parts, subassemblies, housings, guards and protective systems releases the manufacturer from any liability for damage or harm caused.



A change of transported material (quantity, granulation, density, moisture content, temperature and other physicochemical parameters) may affect the efficiency of the separator.



MAGNETIX Sp. z o.o. shall not be liable for accidents and damages resulting from failure to observe this Manual.

2. SAFETY INSTRUCTIONS

2.1 WARNINGS AND SYMBOLS



This warning symbol describes a hazard and provides important information about hazards, as specified in the Manual. When coming across such a symbol, beware of danger, read carefully appropriate information, and inform other operators.



Before proceeding with any work on the separator, make sure that it is disconnected from the power supply so that it cannot be switched on accidentally.

2.2 SIGNS OF DEFECTIVE SEPARATOR OPERATION

- Excessive power consumption limit.
- Temperature rise.
- Excessive vibrations.
- Noise.
- Messages transmitted by the control system.



In case of the above mentioned malfunctioning symptoms, it is necessary to:

- Switch off the separator.
- Notify the manufacturer.
- If necessary, notify the relevant services.



To ensure safety of persons operating the separator and those in its vicinity, the following rules must be observed:

- Read this manual and the safety guidelines it contains.
- Do not entrust the operation of the separator to persons who are not trained in occupational health and safety and fire prevention rules.
- Ensure that the separator is connected to a permanent and effective protective ground.
- Do not operate the separator with guards removed.
- Keep the area around separator clean and tidy.
- Only qualified electricians may repair and maintain electrical equipment.
- Switch the separator off during inspection, maintenance and repairs. Place a “DO NOT ACTIVATE” warning sign on the separator before servicing.

2.3 HAZARDS IN MAGNETIC FIELD

 The separator is a source of a long range constant magnetic field. The safe distance from the source is 1 m. The safety regulations in this manual must be observed!

Safety of persons

- Persons with pacemakers or similar devices must not remain near the magnet (keep safety distance of 1 m).



- It may lead to circulatory and cardiac disorders.
- It is forbidden to stay near the magnet for a long time.
- Staying close to a separator emitting a strong magnetic field: not more than 8 hours per day at a time, at a distance of less than 500 mm from the outline of the magnetic block.
- Magnetic field produced by a permanent magnet attracts tools and clothing parts made of steel. Risk of squeezing or crushing of limbs or other injuries.

Safety of machines and pieces of equipment

- The magnetic field produced by a permanent magnet can disturb or damage electrical and electronic instruments and devices.
- Such devices may be installed or used at a minimum distance of 1 m.
- Place signs to warn of magnetostatic radiation near the separator.

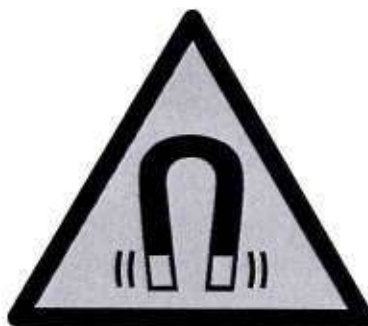

3. APPLICATION AND INTENDED USE

The Magnetic separator type SM is designed to remove ferrous (ferromagnetic) impurities from loose materials transported by gravity. It captures the following impurities:

- Iron impurities of very low weight and surface area, e.g. staples, rivets, wires and filings;
- Iron oxides, rust and other impurities with low magnetic susceptibility;
- Stainless steel particles that have been given magnetic properties by crushing.



The granulation of the transported material must not exceed 5 mm.

The magnetic separator is designed to be installed in vertical gravity transport systems. In the standard version, the separator is available with 2 types of connection flange:

- Circular flange

Insert an illustration

- Square flange

Insert an illustration

The effectiveness of separation depends on:

- the cleaning frequency of the magnetic separator,
- the physicochemical properties of the transported material (in particular the moisture content and the tendency to stick to the surface),
- The degree of contamination of magnetic rods with the product.



The magnetic separator is not designed for cleaning loose materials heavily contaminated with ferromagnetic materials. Using the separator for such materials might lead to:

- decrease in capacity;
- blocking the separator.



The machine is suitable for use in the food industry.



The machine is not suitable for use in the food industry.



Other, non-standard applications require consultation.



A separator may be designed for operation in a hazardous area zone. Information about such a version of the machine is given in the Technical data sheet at the end of this manual.

4. TECHNICAL DESCRIPTION

4.1 MACHINE DESIGN

The magnetic separator type SM consists of:

- Magnetic rods (1)
- Drawers with runners (2)
- Gaskets for drawers (3)
- A dustproof housing (4)

Design variants of the magnetic separator:

- Semi-automatic cleaning.

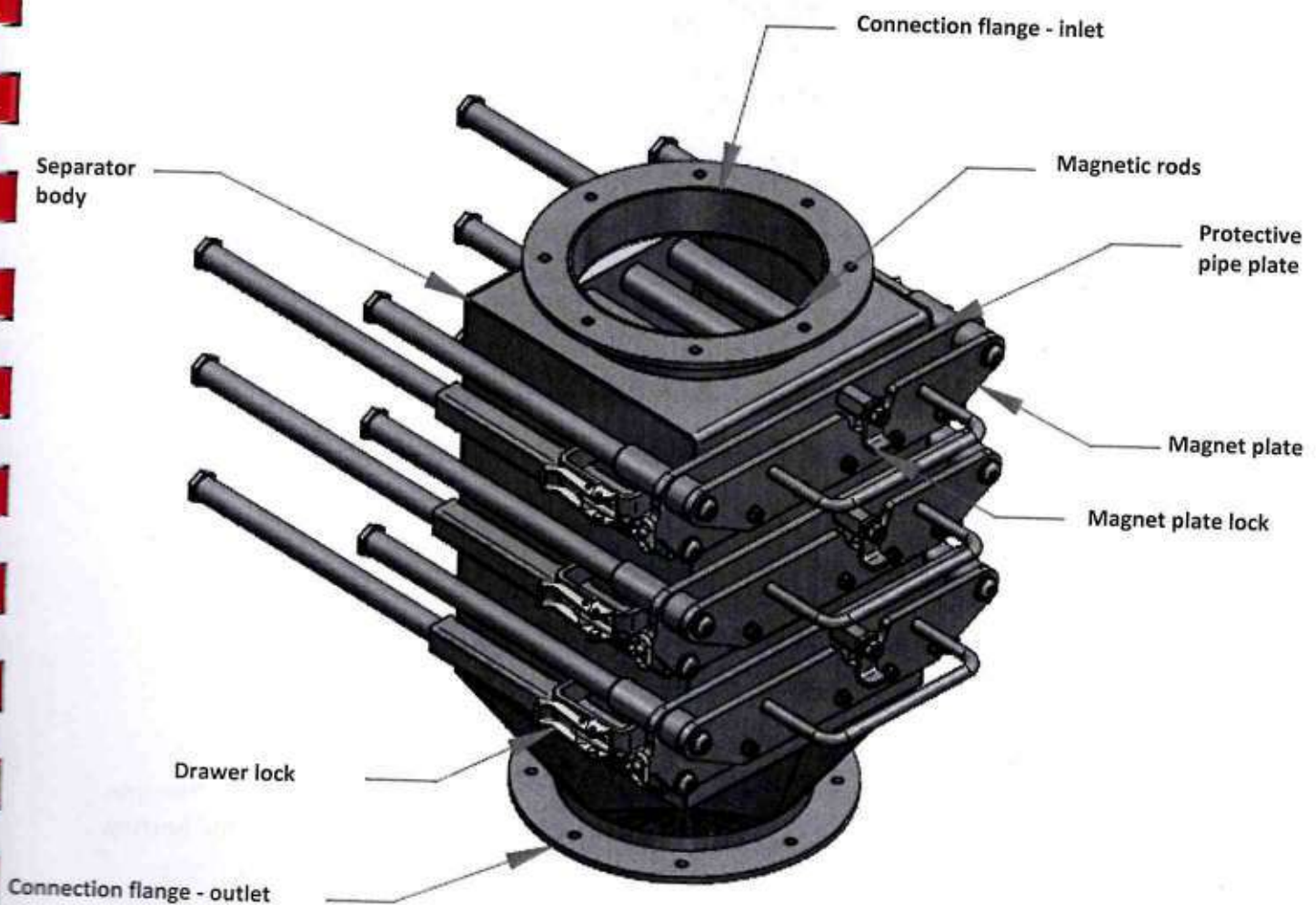

- Manually cleaned.

Differences in the design of manually cleaned and semi-automatic cleaning separators:

- No protective pipe plate;
- No magnet plate locks.

4.2 PRINCIPLE OF OPERATION

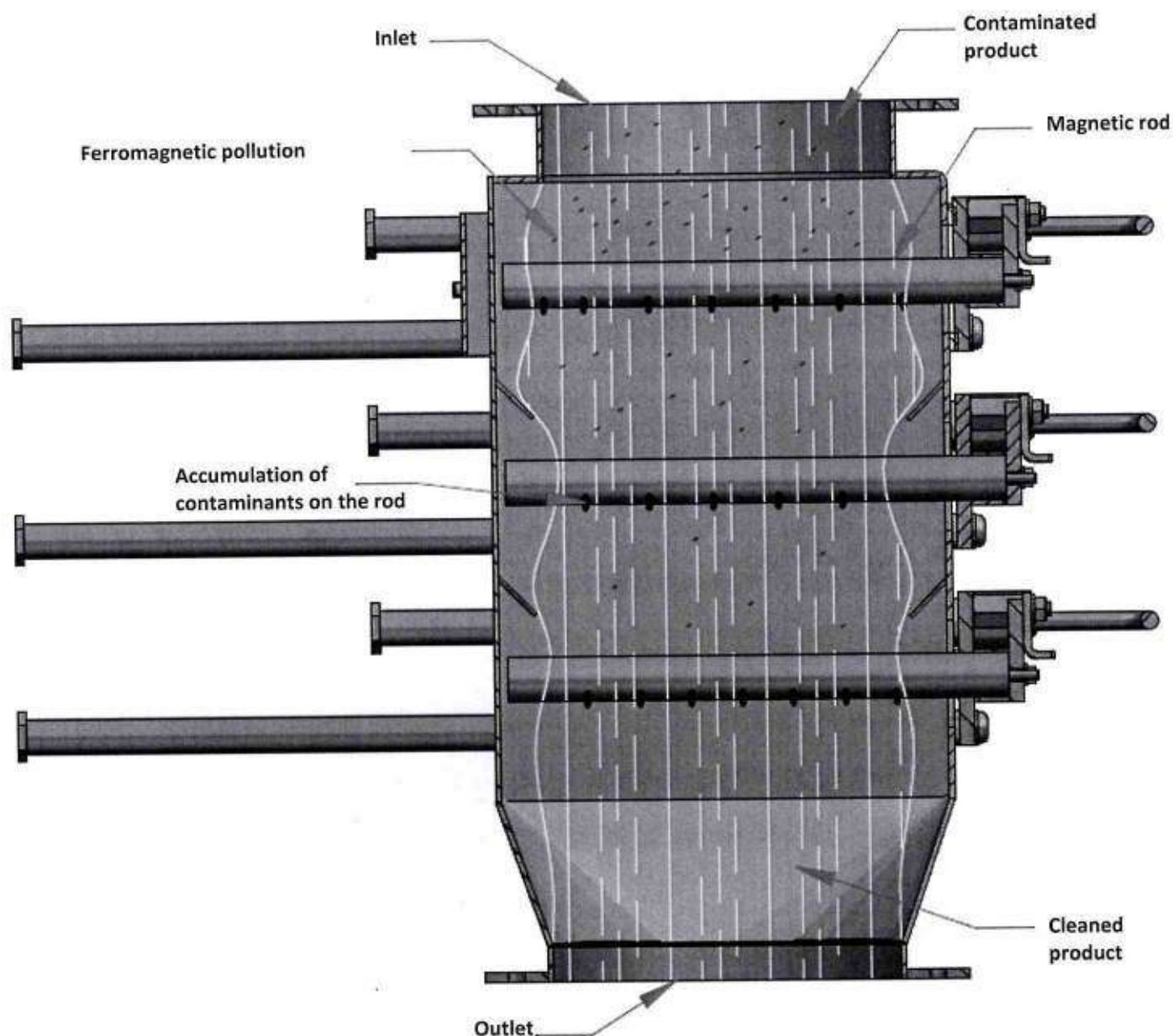

The material being transported is passed through the separator and enters magnetic rods. The iron impurities contained in the material are captured by magnets and accumulate mainly at the bottom of the protective pipes. Then, the cleaned material leaves the separator freely.

4.3 OPERATING CONDITIONS

A standard version of magnetic separator type SM is designed to work at a temperature of max +80°C, which is also the maximum temperature of the product being poured. Optimal working conditions are indoors at room temperature and low air humidity.

The factors which influence the efficiency of neodymium magnets (standard magnetic material for SM separators):

- Ambient temperature +80°C;
- Contact with inorganic acids;
- Contact with bases;
- Contact with water (including damp air).



The magnets must be maintained according to the instructions in the section: Lubrication and Maintenance.

Conditions for the product:

- Loose,
- Moisture content max. 30%,
- Fractional size max. 5 mm (standard).



The moisture content of the transported product must not exceed 30%. The moist material has a greater tendency to stick to the casing pipes, which is the reason for:

- Decreased separation efficiency,
- Decrease of the separator's permeability (in extreme cases, blocking the dump).

5. ASSEMBLY INSTRUCTIONS

 Take special care when installing the separator near structural elements or machines and equipment made of magnetic steel:

- Risk of uncontrolled attraction of magnetic steel elements by a magnet.
- Risk of uncontrolled magnet attraction by magnetic steel components.
- Risk of damage to machines and equipment.
- Risk of injury or serious injury to personnel.

 Keep minimum distance of 1 m from each side of the separator.

Conditions for proper installation of the magnetic separator:

- Installing the machine in a way to ensure safe operation and maintenance.
- Build maintenance platforms if the installation site is placed at the height exceeding 1.6 m (i.e. the maximum level of the lower connection flange).
- Seal the flanged connections with a gasket (or sealant) made of the material compatible with the product to be transported.
- The housing is designed in such a way as to eliminate vibrations from other devices.
- Connect the machine to a system of earthed equalizing connections.
- After installing the machine, place signs to warn of the presence of a magnetic field in a visible place.

 Keep minimum distance of 1 m from each side of the machine.

 Vibration can cause runners, drawers and magnetic rods to unscrew, which will damage magnets over time.

 Warning marking is particularly important for operators using metal tools and people with pacemakers or similar devices.

6. USER MANUAL

6.1 OPERATION

Actions to be taken before the separator is put into operation:

- Check bolted joints,
- Check the safety locks of the drawers before opening,
- Check the locks securing magnetic rods,
- Check the warning signs within the unit.

 **An unclosed drawer or untightened screws on the flange will cause the transported material to spill out.**

Due to the permanent magnets used, the magnetic separator does not require power supply and is completely maintenance-free outside the cleaning process.

6.2 CLEANING

- Semi-automatic cleaning procedure:

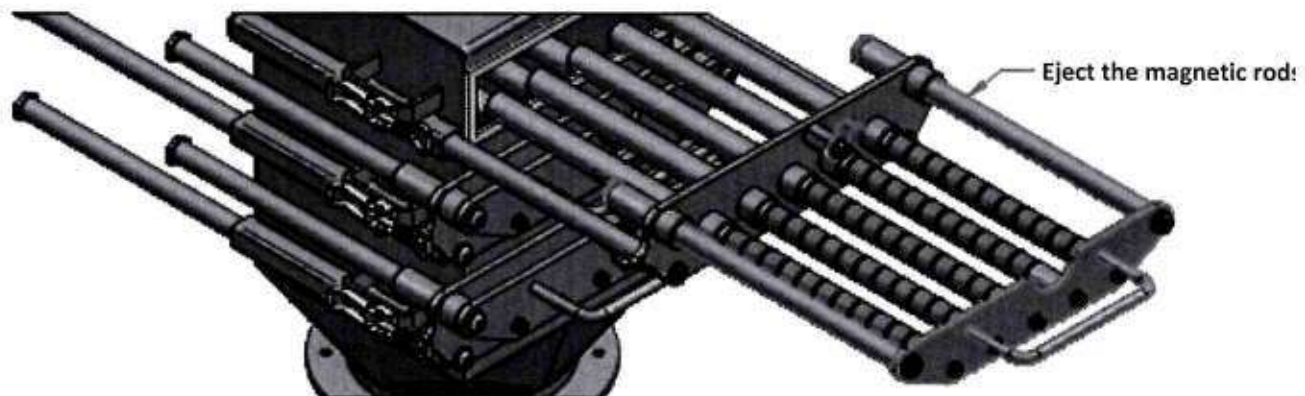
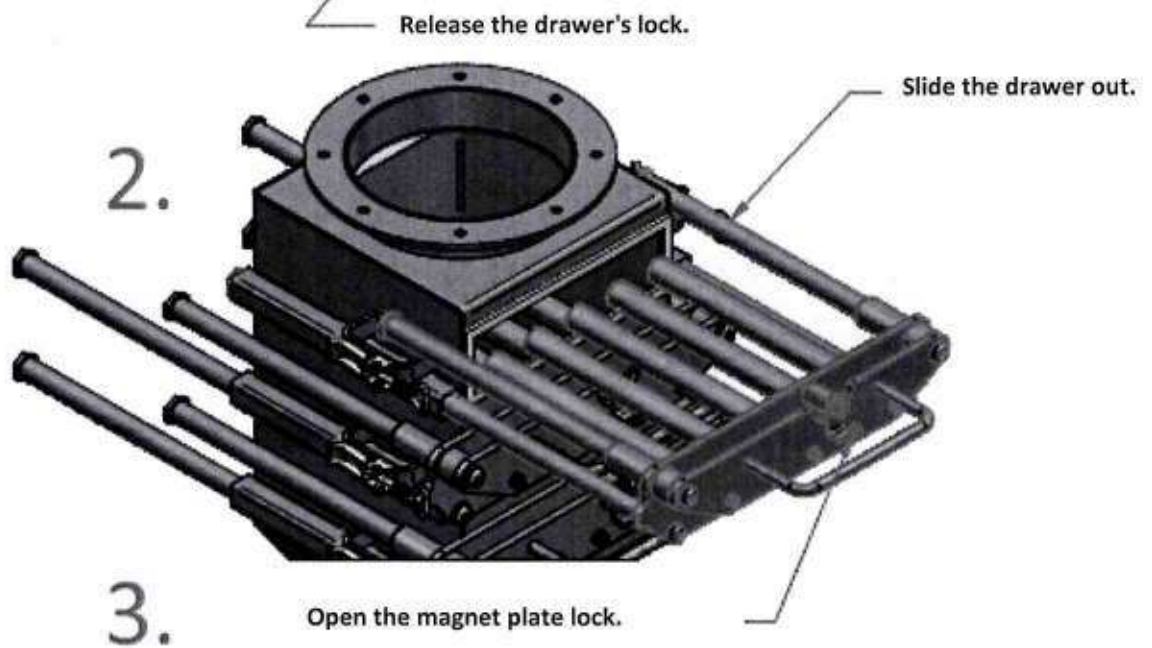
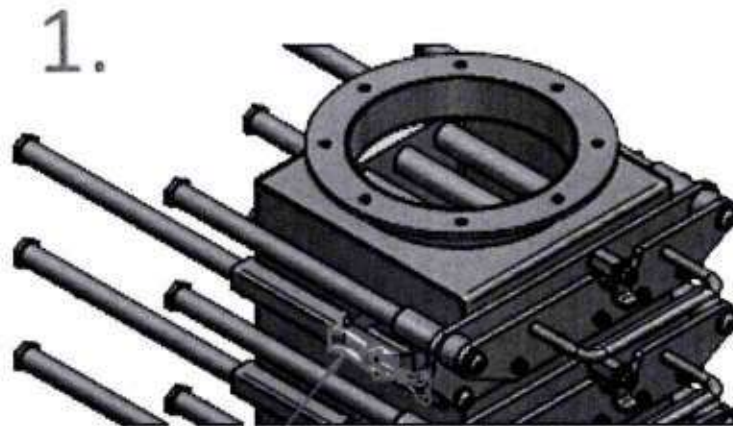

- To close the separator correctly, perform the activities described above in the reverse order.
- Manual cleaning is performed using the same procedure. The procedure is the same with the exception of item 3; the rods must be cleaned manually by an operator with a damp cloth.

Conditions for proper maintenance of the separator:

- Cleaning the separator is possible only with the process line switched off.
- Carry out cleaning regularly.
- Cleaning of magnetic rods from the stuck product.
- Carry out regular inspections to detect entrapped foreign bodies.



Pulling out the drawer while the installation will result in escaping of material being transported to the outside.



The manufacturer is not responsible for accidents or damages caused by incorrect operation of the machine.



The frequency of cleaning depends on the degree of contamination of the transported material. During the initial phase of operation of the magnetic separator, it is recommended to make more frequent inspections.



Lack of regular cleaning leads to a deterioration of the separation efficiency as well as to blocking of the chute.

7. PACKAGING, TRANSPORT, AND STORAGE

7.1 TRANSPORT PACKAGING

As standard, the machine for transport is placed on a wooden pallet and secured with clamping straps. It is also wrapped in polyethylene film to protect the machine from moisture.

7.2 STORAGE

It is recommended to store in a place protected from weather conditions in dry and airy rooms at temperatures from -20°C to $+40^{\circ}\text{C}$.

The storage room must be free of dust, gases, liquids, fumes, caustic fumes, and other aggressive chemicals.

 During storage, place the unit on wooden subfloor in such a way that it does not come into contact with damp substrate. It is also necessary to cover it with a tarpaulin to avoid contamination by metallic dust.

7.3 TRANSPORT

The device should be transported by covered means of transport and should be placed on a transporter so that it is not damaged during transport. The device can be transported over short distances without a roof, but it is necessary to cover it with a tarpaulin or protect it with polyethylene film. Loading, unloading and transport should be carried out in accordance with applicable regulations.

Any damage caused during transport or unloading should be reported immediately to the carrier. Damages reported at a later date will not be taken into account.

 The magnetic separator can be transported by means of slings using the method of attachment shown in the picture. It is forbidden to fix slings to magnetic rods, nuts, locks etc.

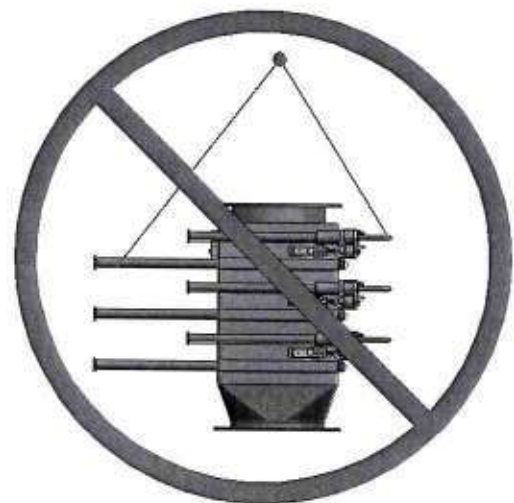
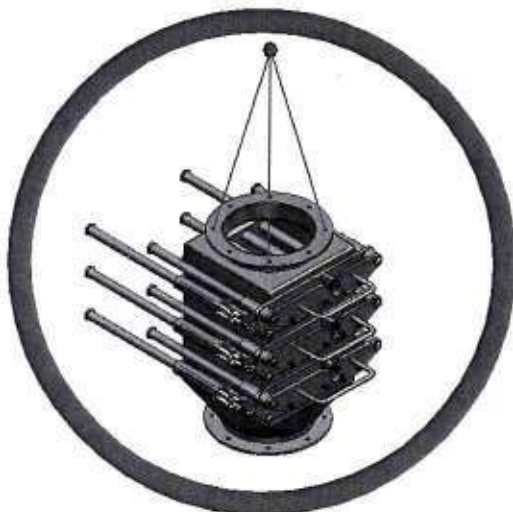



The machine can be lifted by means of lifting devices attached to handles or lugs by authorised personnel, using approved slings with the appropriate lifting capacity (weight of the machine is given in the technical data sheet). Personnel should have knowledge and experience in handling heavy objects.

8. MAINTENANCE AND LUBRICATION INSTRUCTIONS

8.1 MACHINE MAINTENANCE

In order to ensure that the machine is fully operational, inspect it from time to time to check the condition of its individual components:

- Clean the separator regularly, taking care to ensure that the protective pipes are not "clogged" with the transported material, perform cleaning if necessary.
- Check for abrasion or dents in the protective pipes.
- Check the condition of the bolted joints and tighten loose bolted joints.
- Keep the machine properly cleaned and periodically remove dust deposits.

 In order to confirm the high performance of the device, the magnetic field strength should be measured every 12 months. The measurement must be made with a magnetic field meter (tesla meter) adapted for this purpose. The measurement may be carried out by the manufacturer of the equipment or by an authorised testing laboratory.

8.2 LUBRICATION

Most of the magnetic separator components are maintenance free.

The elements of the magnetic cores are coated with a protective coating. Nevertheless, it is necessary to regularly lubricate with commercially available aerosol-based lubricants with additional water displacement properties.

For food industry, use lubricants with appropriate approvals and authorisation for food industry. It is recommended to lubricate the magnetic cores with WURTH "HHS for the food industry" (Art. No: 08931076) or its equivalent.

 Lubrication of magnetic cores is essential in the following cases:

- Long standstills,
- Operation outdoors,
- Operation in unheated halls,
- Operation in damp rooms,
- Operation with product whose moisture is close to the recommended maximum value.

If any of these conditions occur, lubricate the cores every two weeks.

8.3 INSPECTIONS

Subassembly:	Inspection period					
	24 hours	7 days	30 days	3 months	6 months	12 months
Protective pipes	X					
magnets			S*			P
Housing			X			
Bolted joints			X			

Key:

X — visually inspect and possibly clean the component or parts

S — lubricate a component or part

P — measure magnetic induction

*If the separator operates under difficult conditions (see section 8.2), lubricate the cores every two weeks.

The table above shows only recommended time intervals. Depending on the operating conditions of the device, they may be shortened, but should not be longer than the ones given in the table. The above-mentioned activities are to be performed by the user.

 **Keep minimum distance of 1 m from each side of the machine for free access to the unit for inspection and maintenance.**

9. TECHNICAL SERVICE

Any repairs to the device may only be carried out by an authorised service centre of the manufacturer. The User must carry out adjustment and maintenance work on their own.

Magnetix Sp. z o.o.

Cierpice

ul. Poznańska 9

87-103 Toruń 5

Telephone: 56 653 94 40

Telephone: 56 659 17 77

Fax: 56 658 31 19

Email: serwis@magnetix.com.pl

10. TECHNICAL DATA SHEET OF THE DEVICE

Type:	SM 25-2R-DN200
Serial No.:	M21147-1
Year of manufacture:	2021
Operates in an Ex zone:	--
ATEX marking:	--

The machine is not designed for use in potentially explosive environments.

10.1 DIMENSIONS OF THE DEVICE

The dimensions of the device are shown in the technical drawing attached to the manual at the end of the document.

10.2 TECHNICAL DATA

MAGNETIC SEPARATOR	
Type:	SM 25-2R-DN200
Hopper:	250×250 mm
Flow capacity:	35 m ³ /h
Number of drawers with magnetic rods:	2
Number of magnetic rods in drawers:	5+4
Cleaning method for magnetic rods:	Semi-automatic
Threaded rod diameter:	25 mm
Magnetic material:	NdFeB N52
Protective pipes:	1.4404 (AISI 316L)
Screen housing:	1.4301 (AISI 304)
Drawer sealing:	Food grade silicone
Granulation of the cleaned material:	max. 5 mm
Operating temperature:	max. +80°C
Weight:	34 kg

10.3 SPARE AND FAST-WEARING PARTS

Item	Type of part	Quantity
1.	Magnetic core	9
2.	Drawer with protective pipes ⊗	2
3.	Guide rail	4+4
4.	Housing gasket ⊗	1 set
5.	Guiding roller of a drawer ⊗	-

The afore-mentioned spare parts are not included in the scope of delivery, unless it was previously agreed. These parts are available on request.

⊗ Fast-wearing parts.

The warranty does not cover parts, whose natural wear and tear occurs within a period of time shorter than the warranty period.

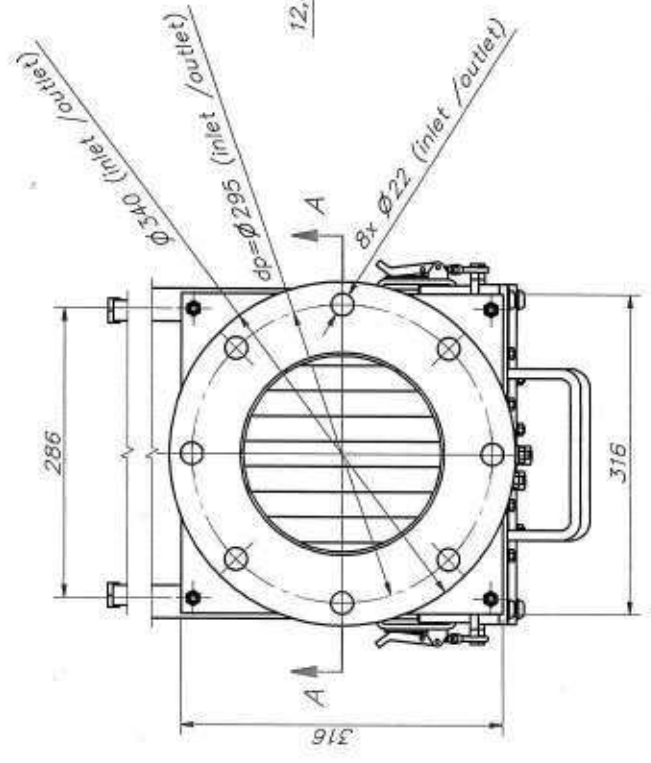
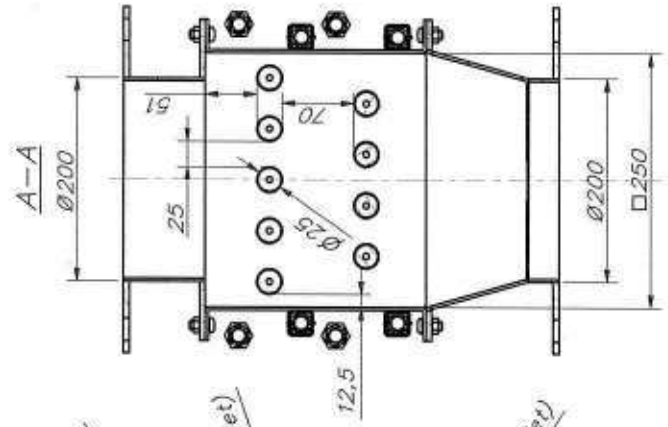
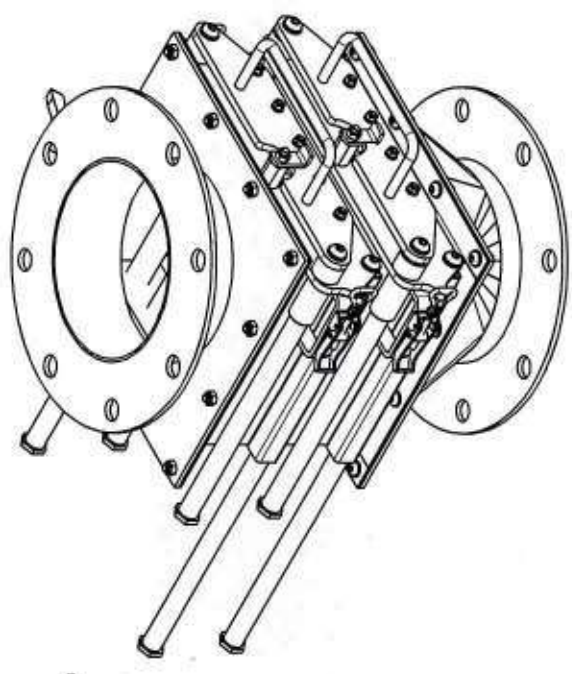
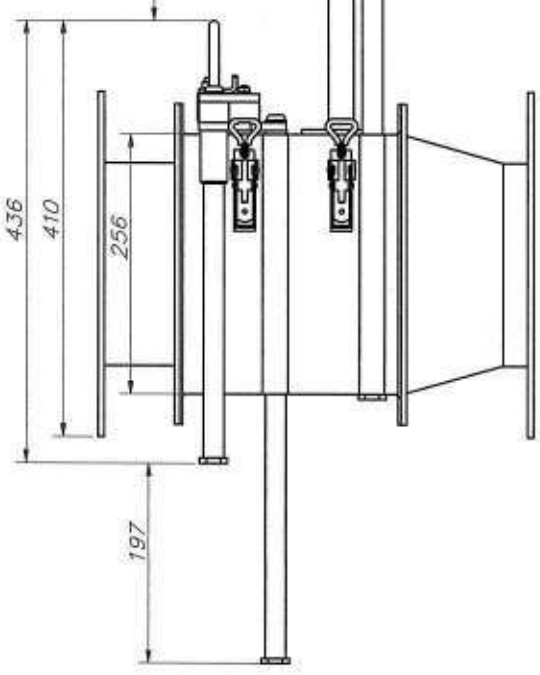
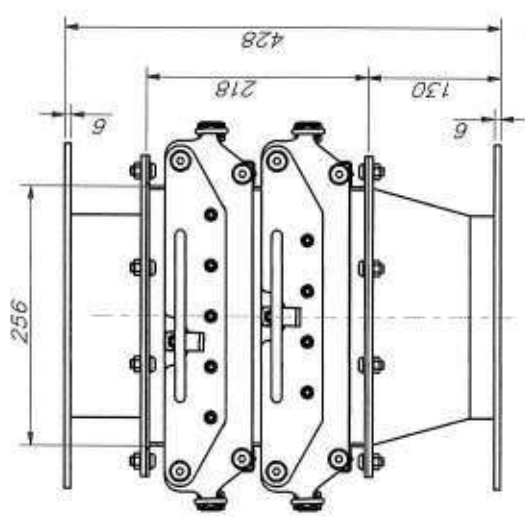

Creation date:	2021-06-21	Order No.:	M 21147
Revision date:		Material:	Quantity: 2
Designed by:		Name:	SM 25-2R
Drawn by:		Revision:	1 / 1
Checked by:		Scale:	1 : 5
 at Pomerania 9, Chępcze 87-103 Toruń 5		Drawing No.:	SM-105.21
		Mass:	

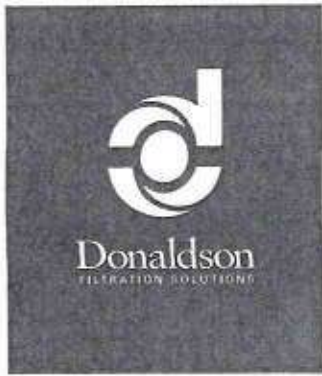

INSTALLATION, OPERATION AND MAINTENANCE MANUAL

Unicell Dust Collector
Series C10-90 (from May 2007)

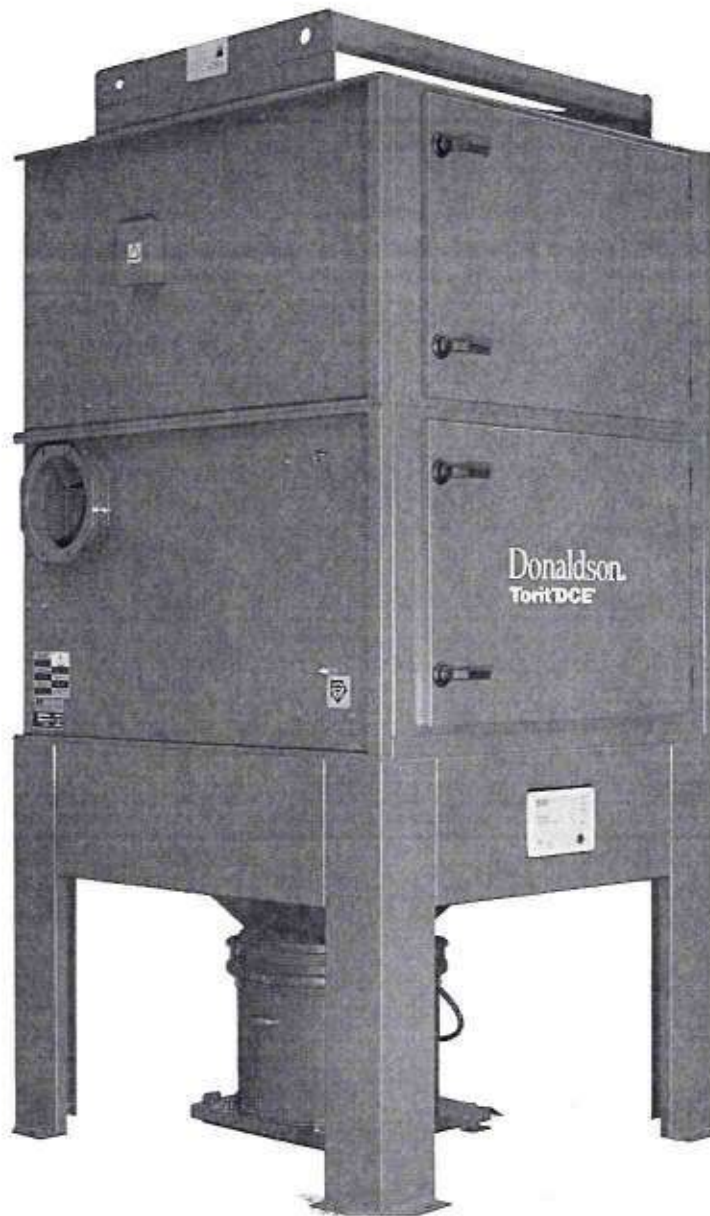

GB

EU DECLARATION OF CONFORMITY

(Machinery Directive 2006/42/EC)

Manufacturers: **Donaldson Filtration GB Ltd.**
Humberstone Lane, Thurmaston, Leicester LE4 8HP, England
ISO Certificate number: BE09/961048.03

Donaldson Industrial CR - s.r.o.
Kralovsky vrch 1986, 432 01 Kadan, Czech Republic
ISO Certificate number: BE09/961048.06

Donaldson Middle East Filtration Systems LLC
107B8 Industrial City of Abu Dhabi #1
PO Box 46958, Abu Dhabi, United Arab Emirates
ISO Certificate number: 44 100 090667

Technical file (Head Office): **Donaldson Europe B.V.B.A.**
Interleuvenlaan 1, B-3001 Leuven (Heverlee), Belgium
ISO Certificate number: BE09/961048.01

Description of the machinery: **Dust Collector, Oil/Mist Collector**

Brand: **Donaldson Torit DCE**

Description: **See Scope of Delivery**

Serial number: 36436506

This Declaration of Conformity is issued under the sole responsibility of the manufacturer.

The undersigned, authorized by Donaldson, certifies that the machine described above, provided that it is installed, maintained and used in accordance with the instructions for use and the codes of practice, meets the essential safety and health requirements of the following Directives:

Machinery Directive 2006/42/EC
Low Voltage Directive 2014/35/EU ¹
Pressure Equipment Directive 2014/68/EU ¹
Electromagnetic Compatibility Directive 2014/30/EU ¹
Equipment and protective systems intended for use in potentially explosive atmospheres ATEX Directive 2014/34/EU ¹
¹ Directive only applicable as defined by the Scope of Delivery.

IMPORTANT! Read the Installation, Operation and Maintenance Manual for order specifics and before using this machine. If you require additional copies contact your local Donaldson representative.

If the Donaldson product is part of a system then it must not be put into service until the machinery into which it is to be incorporated has been declared in conformity with the provisions of the above mentioned directives.

For connection to a power supply refer to appropriate manual.

Signature:



Name: David Gutman

Place: Leuven, Belgium

Position: Engineering Manager

Date: January 2019

○ **Donaldson**
Torit[®] DCE[®]



DONALDSON FILTRATION (GB) LIMITED
Humberstone Lane, Thurmaston, Leicester, LE4 8HP, England
TEL: +44 (0) 116 269 6161 • FAX: +44 (0) 116 269 3028
EMAIL: IAF-uk@donaldson.com • www.DonaldsonToritDCE.com



06 2021

MODEL
MODELL
МОДЕЛЬ

C90HK21

SERIAL NUMBER
SERIENNUMMER
ЗАВОДСКОЙ НОМЕР

36436506

400 V
B

3 ~

50 Hz
Гц



18.5 kW
кВт

SUPPLIED WEIGHT
LIEFERGEWICHT
ВЕС ОБОРУДОВАНИЯ

1085 Kg
кг

ORDER NUMBER
BESTELLNUMMER
ЗАКАЗ НОМЕР

15257270

CU Legal Entity:

Limited Liability Company ITC

Location: Russia, 423815,
Republic of Tatarstan, Naberezhnye Chelny,
Ave. Chulman, Building 128, office 230

Registration Numbers: INN/KPP 1650079320/165001001

CONTENTS

SAFETY RECOMMENDATIONS	4
Applications having a risk of sparks and fires	6
INSTALLATION	7
General guidance to lifting	10
Standard collectors with dust container or rotary valve	11
Venting type collectors with dust container or rotary valve	12
Hopper type and venting type collectors	14
Pressure balance pipe	14
Compressed air requirements	15
Control equipment connection	16
Controller	16
Overload protection	17
Integral fan	17
Interlocks	17
EEx controls	18
PT Controller	18
Antistatic earthing	19
Explosion relief	19
Secondary or absolute filter monitor	19
Installation check list	20
COMMISSIONING	21
Commissioning check list	21
Start-up sequence	22
Shut-down sequence	22
OPERATION	23
Principle of operation	23
Dust disposal	24
MAINTENANCE	25
Routine inspection	25
Servicing schedule	26
Fan assembly removal/replacement	28
Secondary or absolute filter replacement	29
SPECIFICATION	32
Description and range	32
Construction	32
DECLARATION OF CONFORMITY	A1

SAFETY RECOMMENDATIONS



The dust collector should be used only when it is in a technically acceptable condition. Regular maintenance, as set out in this manual, is required to minimise technical failure. Third party supplied components (for example motors) should be maintained according to the manufacturer's instructions.



You should ensure any persons carrying out work on the supplied equipment follow any relevant recognised standards/codes and are competent to do so. Areas requiring a competent person include:

- Maintenance on any component identified as a potential ignition source.
- Lifting and erection.
- Electrical installation, inspection and maintenance work.
- Pneumatic installation, inspection and maintenance work.
- Any access to internal classified potentially explosive atmospheres where there may be a risk due to explosion.

During assembly/installation or dismantling of equipment, potential ignition sources may occur that were not considered in the risk assessment of the unit in operation (for example, grinding, welding sparks, etc.)



You should use the dust collector in full accordance with the conditions set out in the Order Acknowledgment and relevant Scope of Delivery. Failure to do so may compromise product reliability, warranty and safety. The Scope of Delivery is an integral part of the manual.



Other items of equipment, not supplied under the Scope of Delivery from Donaldson, should be installed, operated and maintained according to the documentation supplied with the respective equipment.



Any modification carried out on the 'as supplied' equipment may reduce reliability and safety, and will nullify warranty; such actions fall outside the responsibility of the original supplier.



Where necessary for safety, the dust collector is fitted with fixed guards. Removal of these guards and any subsequent work should only be carried out after adequate precaution is taken to ensure it is safe to do so. All guards should be refitted before re-energising.



Compressed air is recommended for collectors that operate using reverse jet cleaning. Alternative gases should be assessed before use to ensure that explosive atmospheres are not introduced during media cleaning.



Where the equipment supplied is suitable for working within a potentially explosive atmosphere (as defined by Directive 2014/34/EC) it will be according to the categories and conditions marked on the collector serial nameplate. You should ensure the equipment supplied by others is also suitable. If no marking is given on the serial nameplate then the supplied equipment is not suitable for use in potentially explosive atmospheres.



Care should be taken to ensure that any potentially explosive atmosphere is not present when performing operations that increase the risk of ignition (opening of controller for adjustment or electrical repair for example). Ensure the installation is always returned to its original state.



Where the dust being processed can ignite due to exothermic reaction, including self ignition, the collector **MUST** be fitted with a suitable explosion protection method (venting for example). The risk of ignition can be minimised by avoiding the accumulation of dust layers with regular cleaning.



The dust collector may be fitted with explosion protection in the form of a vent panel. Precautions, as set out in the Scope of Delivery, are used to minimise the risk of ignition of any dust clouds contained within the dust collector. The possibility of other ignition sources being introduced into the collector during periods where any dust cloud may be present should be minimised. Particular care should be taken to avoid introducing glowing particles via the collector inlet ducting.



The explosion relief assembly, where fitted, has been designed to provide adequate safety from an explosion initiated from within the collector, for the given dust explosion characteristics and collector arrangement as set out in the Scope of Delivery. You should ensure that explosions are not allowed to propagate into the dust collector (using suitable isolation devices) since pressures may be generated leading to unsafe equipment rupture.



Where applicable, equipment connected to the dust collector (for example, a cyclone) should be protected, using suitable isolation devices, against the transfer of flame and pressure if, in the event of an explosion initiating inside the dust collector, the connected equipment is not capable of safely withstanding these effects.



The explosion relief assembly, where fitted to the dust collector, is not suitable for use with dusts that are classified as poisonous, corrosive, irritant, carcinogenic, teratogenic or mutagenic unless the dust released during the explosion venting process can be contained to a safe level.



Where applicable, care is required when siting the dust collector to ensure that the effects (flame, pressure, noise and fire) produced during and after the explosion venting process do not put at risk personnel and nearby plant.



In order to ensure the required venting efficiency is maintained, the explosion relief assembly, if fitted to the collector, should not be obstructed in any way.



It may be necessary to provide a facility to shut down the equipment in the event of an explosion (where collectors are fitted with explosion relief panels). The signal should be taken from the bursting panel detection device.

Applications having a risk of sparks and fires

1. Good Housekeeping

Accumulation of potentially combustible dust, for example dust layers is considered a potential ignition source. Failure to keep the dust collector clean and empty the hopper / dust bins regularly will increase the risk of fires and/or explosions.

2. EU Directive 99/92/EC

A reinforced and/or vented dust collector must be used when handling dusts that have the potential to form an explosive atmosphere. If a non-reinforced and/or non vented dust collector is used on these applications then the end user must ensure an equivalent, secure, and fool proof basis of safety, which must be clearly documented in the end users Explosion Protection Document in line with Article 8 of EU Directive 99/92/EC.

3. Self Heating Materials

Please note that some materials have the potential to self generate heat and hence to become an ignition source, that could result in a fire and /or an explosion. For this reason ferrous and non-ferrous materials should not be extracted in to the same dust collector, as when combined they can create a violent thermite reaction that would ignite a fire and/or explosion.

4. Applications having a risk of sparks and fires

Where sparks are generated by the process, this must be considered as a potential ignition source which increases the risk of a fire or explosion. The filter can be supplied with an optional spark trap to help reduce the frequency of spark ignition and should be regarded as part of a risk reducing strategy.

The spark trap is not an extinguishment system and should never be relied upon to achieve spark eradication in processes where suppression requirements are absolute. The spark trap does not guarantee complete elimination of sparks and does not preclude the possibility of fire or explosion. Therefore, system redundancy and complementary measures should be taken in conjunction with the spark trap to further reduce the risk of fire and explosion from sparks in applications where there is potential for catastrophic combustion.

On these types of applications the enduser should carry out regular good housekeeping, such as:

- Periodically check for dust fall out in ducting and remove.
- Pulse down off line regularly to minimise retention of dust cake on filter cartridges.
- Empty dust bins frequently.

Other risk reducing strategies could include:

- Inject with an inert material.
- Consider additional spark detection and fire suppression equipment.

INSTALLATION

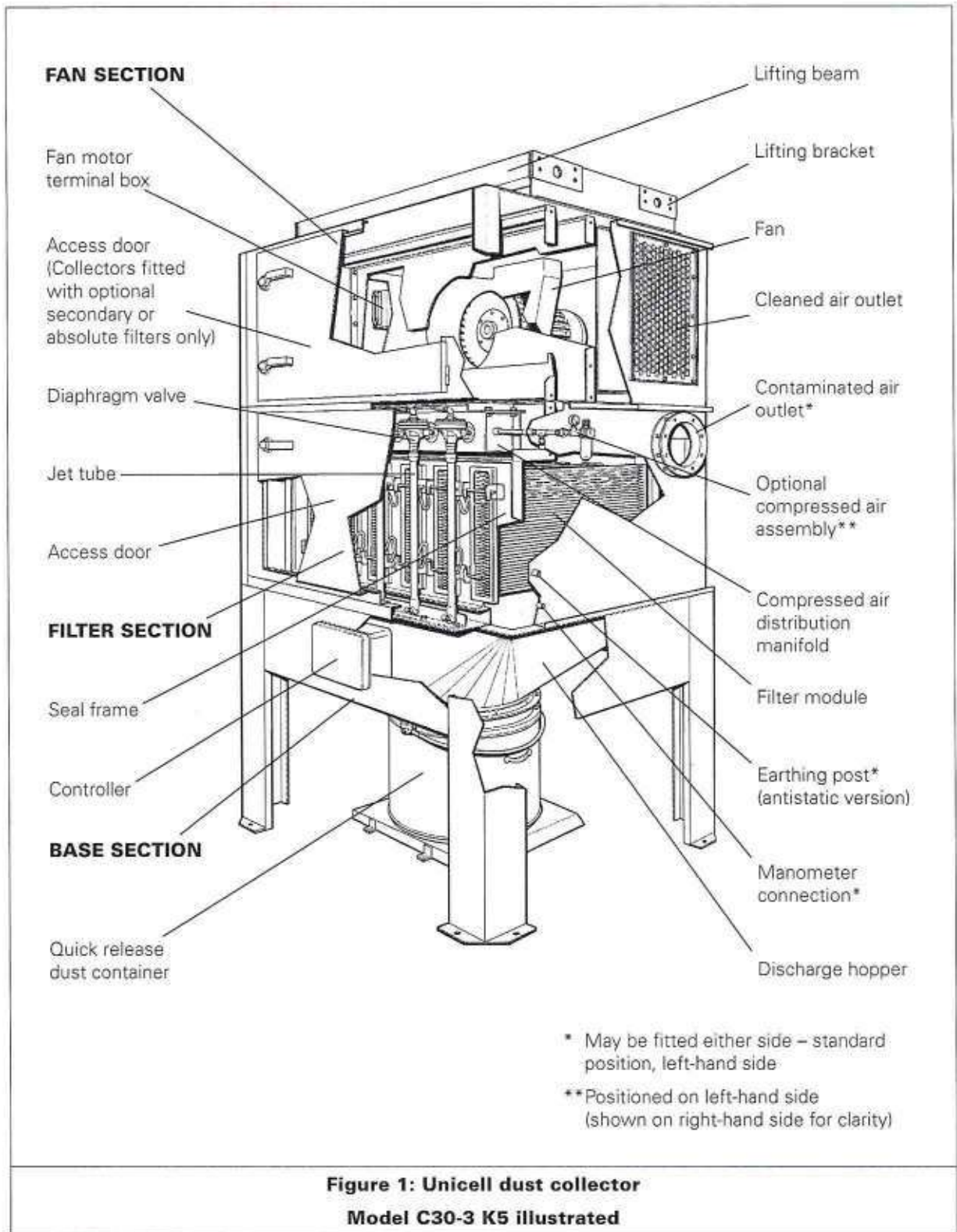



Where equipment is installed in a Potentially Explosive Atmosphere, care should be taken not to locate the collector where external ignition sources can be introduced, for example stray electric currents, lightning, electromagnetic waves, ionising radiation, ultrasonic waves.

Unicell dust collectors are supplied in a number of factory assembled sections, as outlined in Table 1.

TABLE 1 - UNICELL COLLECTOR DELIVERY INFORMATION

C10-30 hopper type dust collector (C10 H, C20 H and C30 H) C10-90 venting type dust collectors (C10 V, C20 V, C30 V, C40 V, C50 V, C60 V, C75 V and C90 V) C10-30 venting type dust collectors with dust container (C10-3 V, C20-3 V and C30-3 V)	Supplied fully assembled
C10-30 standard dist collectors with dust container (10-3, C20-3 and C30-3) C10-30 standard dust collectors with rotary valve (C10 R, C20 R and C30 R)	Supplied in two sections: <ul style="list-style-type: none"> • Base section • Combined filter and fan section
C40-90 venting type dust collectors with dust container (40-3 V, C50-3 V, C60-3 V, C75-3 V and C90-3 V) C10-90 venting type dust collectors with rotary valve (C10 VR, C20 VR, C30 VR, C40 VR, C50 VR, C60 VR, C75 VR and C90 VR)	Supplied in two sections: <ul style="list-style-type: none"> • Base section • Filter section
C40-90 hopper type dust collectors (C40 H, C50 H, C60 H, C75 H and C90H)	Supplied in two sections: <ul style="list-style-type: none"> • Filter section • Fan section
C40-90 standard dust collectors with dust container (C40-3, C50-3, C60-3, C75-3 and C90-3) C40-90 standard dust collectors with rotary valve (C40 R, C50 R, C60 R, C75 R and C90 R)	Supplied in two sections: <ul style="list-style-type: none"> • Base section • Filter section • Fan section

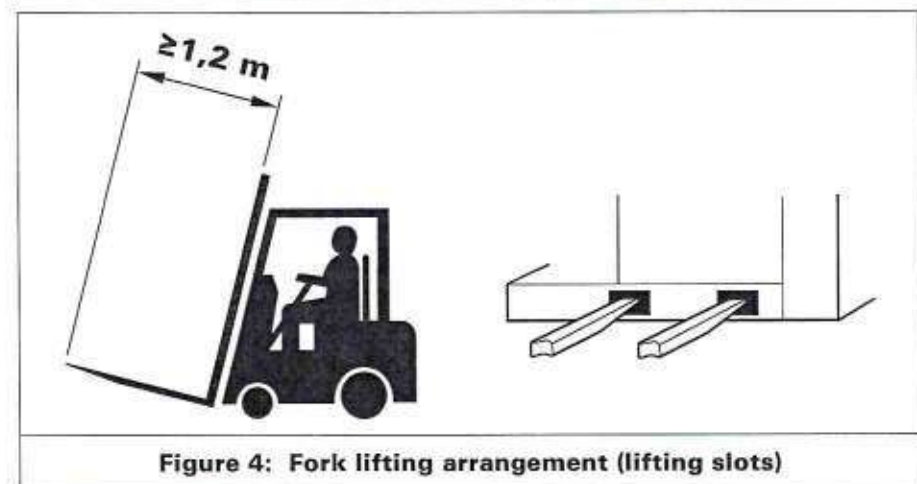
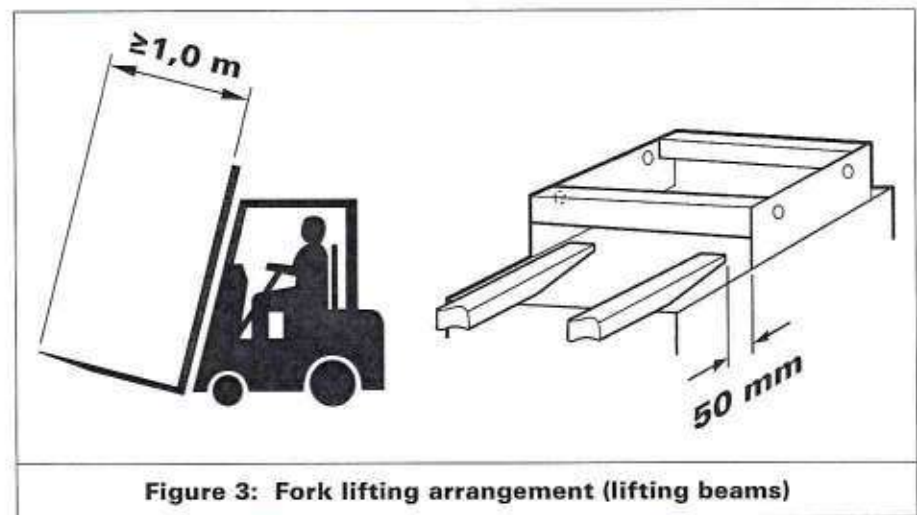
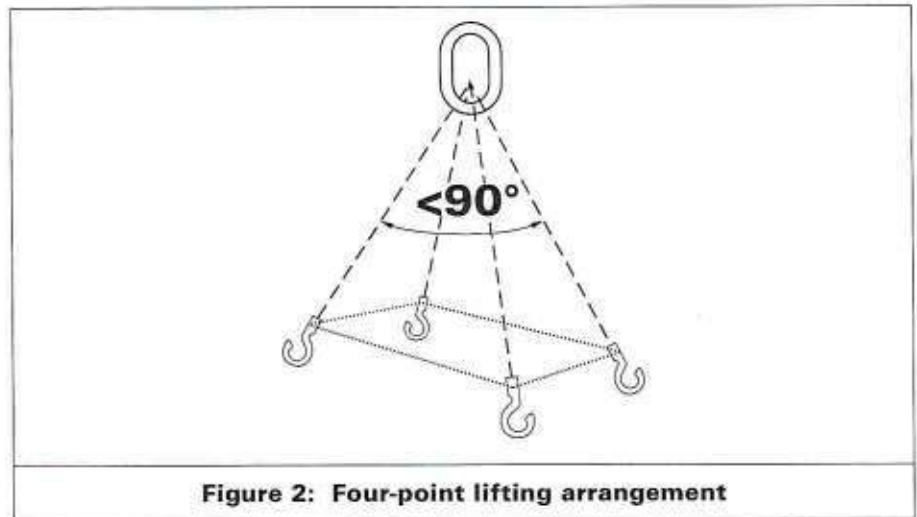

General guidance to lifting



All assemblies should be lifted using either the four-point lifting arrangement or the fork lifting arrangement.

If advantageous, the filter and fan sections may be fitted together prior to lifting onto the base section.

Four-point lifting arrangement (Fig. 2)

Lifting brackets are fitted to all sections.



Chains or slings with an adequate SWL (safe working load) must be used. (Refer to lifting label located adjacent to lifting bracket for weight of equipment supplied by Donaldson). Chains must be long enough to ensure that the included angle between diagonal chains is not greater than 90°.

Ideally the chains should be adjusted to give a horizontal lift. If the chain lengths are not adjusted the equipment will hang at an angle but can still be lifted safely.



The lifting brackets should only be used to lift the equipment as supplied, i.e. not with any ancillary equipment fitted.



If four-point lifting method is used on C40-90 collectors, then the fork lifting slot cover plates, located on both sides of the fan section, should be removed and replaced using sealant to ensure an effective seal.

Fork lifting arrangement (Figs. 3 and 4)

C10-30 collectors: Lifting beams are located at the top of the fan section or, on venting type collectors, at the top of the filter section.

C40-90 collectors: Lifting slots are located on both sides of the fan section (behind cover plates).



A fork lift with an adequate SWL (safe working load) must be used. The forks must also be of a suitable length and adjusted to ensure a stable lift. (Refer to lifting label located adjacent to fork lifting points for weight of equipment supplied by Donaldson and for minimum fork lengths and positioning).



When using lifting slots, remove all four cover plates before lifting.



If fork lifting method is used on C40-90 collectors, then the fork lifting slot cover plates should be replaced using sealant to ensure an effective seal.

Standard collectors with dust container or rotary valve

C10-30 collectors:

Lift the base section into position and, using plumb lines and spirit levels, line up both horizontally and vertically using shims under legs where required. Drill through the base section holes and insert and tighten expandable bolts (if required, details of foundation fixing positions are provided in Publication 2710). For collectors with dust container, locate position for dust container base panel, drill through fixing brackets and secure with bolts. Adjust height to provide an effective seal between dust container and sealer gear.

Remove lifting brackets from base section and apply sealing compound around the flange making a continuous 5 mm bead along each side of the holes (see Fig. 5). Lift the combined filter and fan section into position and secure using nuts, bolts and washers to form an airtight seal.



A number of fixings are positioned within the cleanside of the filter section. On C10-30 collectors the jet tubes and jet tube locator bracket should be removed to gain access to the cleanside front flange (see Fig. 6). Ensure these fittings and gasket are refitted correctly.



When the collector is fitted with antistatic filter modules, an earthing connection must be made between the base and filter sections, using the earthing strap provided (see Fig. 7).

C40-90 collectors:

Lift the base section into position and, using plumb lines and spirit levels, line up both horizontally and vertically using shims under legs where required. Drill through the base section holes and insert and tighten expandable bolts (if required, details of foundation fixing positions are provided in Publication 2710).

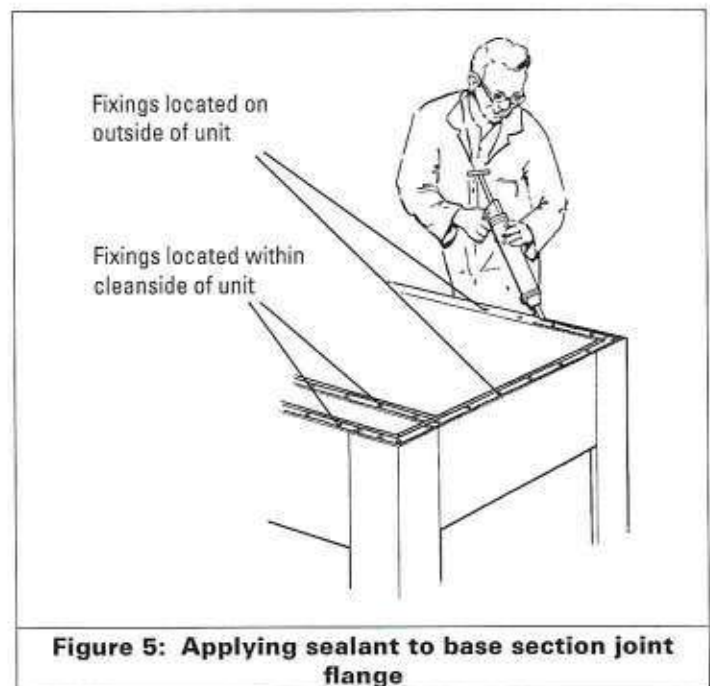

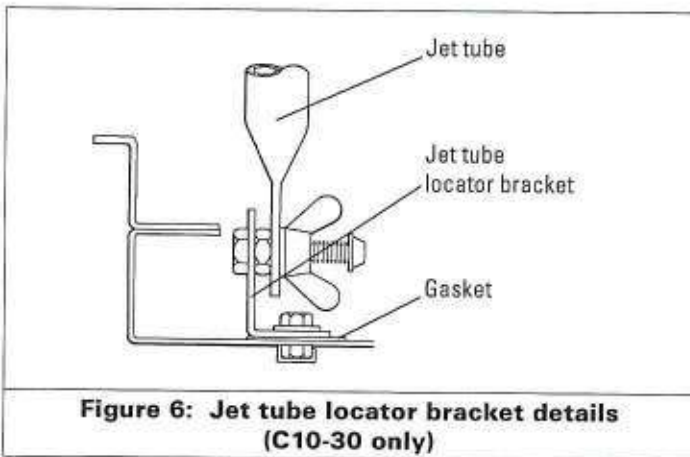

For collectors with dust container, locate position for dust container base panel, drill through fixing brackets and secure with bolts. Adjust height to provide an effective seal between dust container and sealer gear.

Remove lifting brackets from base section and apply sealing compound around the flange making a continuous 5 mm bead along each side of the holes (see Fig. 5). Lift the filter section into position and secure using nuts, bolts and washers to form an airtight seal.

Remove lifting brackets from filter section and, repeating the procedure above, fit the fan section.



When the collector is fitted with antistatic filter modules, an earthing connection must be made between the base and filter sections, using the earthing strap provided (see Fig. 7 and 8).

Venting type collectors with dust container or rotary valve

C10-30 venting type collectors with dust container:

Lift the collector into position and, using plumb lines and spirit levels, line up both horizontally and vertically using shims under legs where required. Drill through the base section holes and insert and tighten expandible bolts (if required, details of foundation fixing positions are provided in Publication 2710).

Locate position for dust container support panel, drill through fixing brackets and secure with bolts. Adjust height to provide an effective seal between dust container and sealer gear.

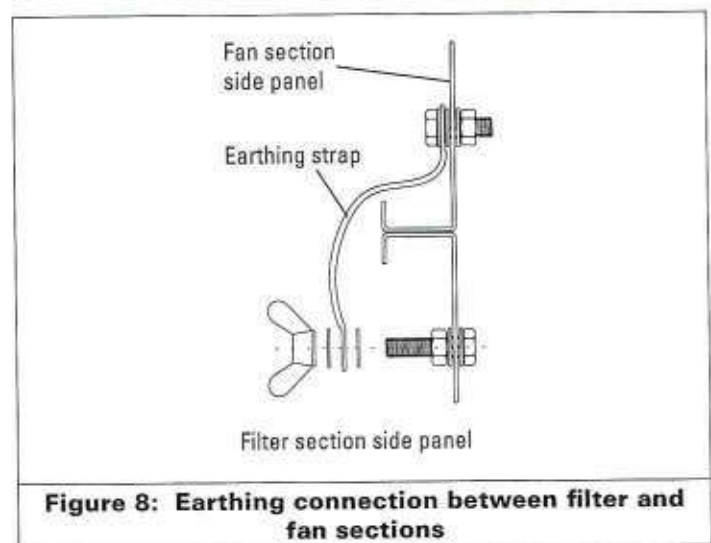
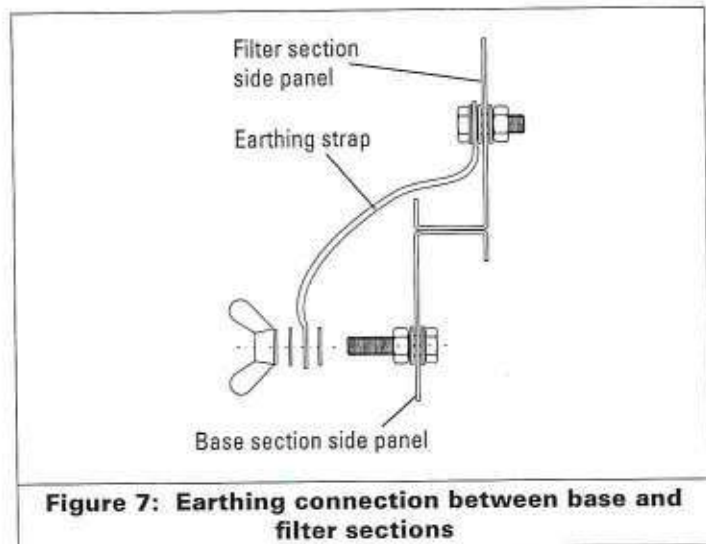

C40-90 venting type collectors with dust container and

C10-90 venting type collectors with rotary valve:

Lift the base section into position and, using plumb lines and spirit levels, line up both horizontally and vertically using shims under legs where required. Drill through the base section holes and insert and tighten expandable bolts (if required, details of foundation fixing positions are provided in Publication 2710). For collectors with dust container, locate position for dust container support panel, drill through fixing brackets and secure with bolts. Adjust height to provide an effective seal between dust container and sealer gear.

Remove lifting brackets from base section and apply sealing compound around the flange making a continuous 5 mm bead along each side of the holes (see Fig. 5). Lift the filter section into position and secure using nuts, bolts and washers to form an airtight seal.



A number of fixings are positioned within the cleanside of the filter section. On C10-30 collectors the jet tubes and jet tube locator bracket should be removed to gain access to the cleanside front flange (see Fig. 6). Ensure these fittings and gasket are refitted correctly.



When the collector is fitted with antistatic filter modules, an earthing connection must be made between the base and filter sections, using the earthing strap provided (see Fig. 7 and 8).

Hopper type and venting type collectors



When the collector is fitted with explosion relief panels, the explosion relief area is suitable for the collector volume only. Additional protection may be required when mounting onto other vessels.

Apply sealing compound around the mounting flange making a continuous 5mm bead of sealant along each side of the holes (if required, details of mounting flange fixing positions are provided in Publication 2710).

C10-30 hopper type and C10-90 venting type collectors:

Lift the collector into position and secure using nuts, bolts and washers to form an airtight seal.

C40-90 hopper type collectors:

Lift the filter section into position and secure using nuts, bolts and washers to form an airtight seal. Remove lifting brackets from filter section and apply sealing compound around the flange making a continuous 5 mm bead along each side of the holes. Lift the fan section into position and secure using nuts, bolts and washers to form an airtight seal.



When the collector is fitted with antistatic filter modules, an earthing connection must be made between the filter and fan sections, using the earthing strap provided (see Fig. 8).

Pressure balance pipe

When this option is fitted, the dust container may be lined with a polythene bag which can be closed and sealed before lifting out of the container to assist in the safe removal of toxic or noxious dusts. The containers supplied for this purpose are fitted with a detachable pressure balance pipe to prevent the bag from being drawn up into the collector.

To assemble the pressure balance pipe, the following procedure should be used (refer also to Fig. 9):

1. On C10-30 collectors only, fit the cloth sock filter assembly through the righthand hole in the clean air chamber base.
2. On C10-30 collectors only, fit the balance spigot assembly underneath the clean air chamber base, clamping the cloth sock filter between the clean air chamber base and the bin balance spigot using M8 fixings.



Collectors requiring earthing should use serrated washers on one joint. In this instance the pressure balance pipe will be supplied in a conductive form.

3. Slip the worm drive hose clip over one end of the pressure balance pipe.
4. Slide the pressure balance pipe over the pipe connection on the dust container.
5. Position the worm drive hose clip to suit and tighten until sufficiently secured.
6. Take the other end of the pressure balance pipe and slip the worm drive hose clip over it.
7. Slide the pressure balance pipe over the bin balance spigot assembly.
8. Position the worm drive hose clip to suit, and tighten until sufficiently secured.

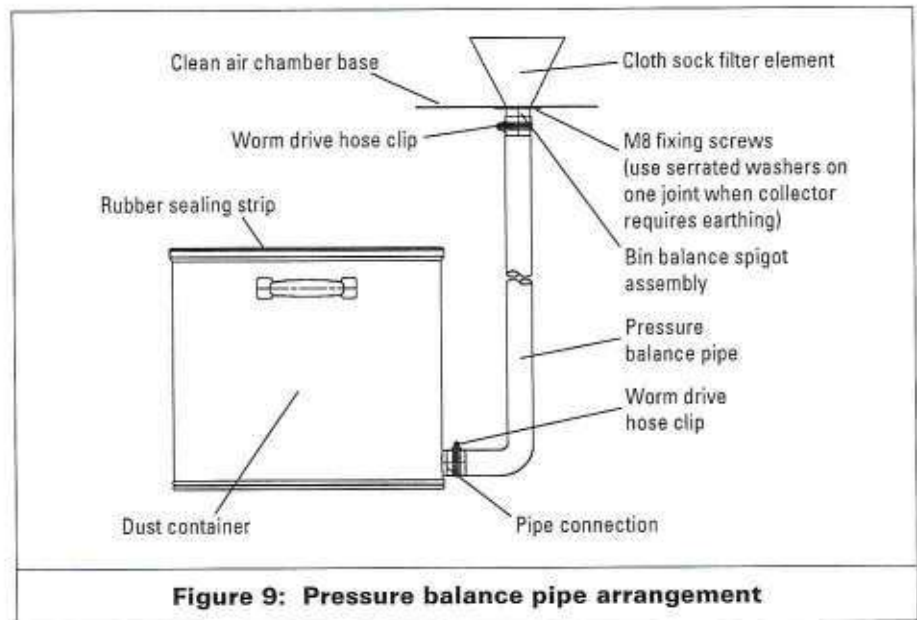

Compressed air requirements

Unicell dust collectors require an independent supply of clean, dry, oil-free compressed air. Details of atmospheric pressure and quantity are given in Table 6 (refer to 'Specification' section). A design label is also attached to each manifold. Where an existing factory mains system is to be used it may be necessary to install an additional moisture separator in the supply line to the unit.

If a compressor is being installed to supply the unit, then the following conditions should be observed as far as possible:



Alternative cleaning gases should be assessed before use to ensure explosive atmospheres are not introduced.

Type of compressor

Use a compressor of ample capacity – an overloaded compressor tends to produce excessively contaminated, moisture-laden air.

Location of air intake

Avoid locating the air intake in an excessively polluted area and install an adequate air intake filter. The compressor air intake should be sited, if possible, on the north side of the building – fresh air drawn from the north side is usually cooler and denser, and therefore has a lower moisture content. (South of the equator the reverse will apply).

Layout and installation of air lines

The pipework between compressor and dust collector should be long enough to act as a cooling device for the compressed air. A typical requirement for the smaller installation would be 10 m (30ft) of 12 mm ($\frac{1}{2}$ " NB) piping. For further details see Table 6. The piping should be installed to provide a fall in the direction of air flow to assist in the drainage of accumulated moisture. A moisture separator should be provided at the lowest point of the installation.

Pressure relief

The manifold has a maximum operating pressure of 6.2 bar (see Table 5 in 'Specifications' section). It is a requirement that adequate precaution is taken to avoid exceeding this pressure. Where a relief valve is supplied by Donaldson this device has a relief rating of 17 dm³/s at 6.9 bar. Extra system relief will be required if the connected supply can exceed this.

Control equipment connection

This connection only applies to C10-30 standard collectors with dust container or rotary valve and C10-30 venting type collectors with rotary valve. Using the tubing supplied, push-fit one end of each tube to the tubing connectors underneath the clean air chamber base, starting from the left-hand side (see Fig 10). Connect each tube to the controller by push-fitting to the corresponding solenoid pilot valve projecting from the controller (valves are numbered in sequence from the left, see Figure 11 for typical arrangement). Ensure each tube is firmly connected to the valve.

Controller



It is a requirement of the Supply of Machinery (Safety) Regulations 1992 to provide adequate isolation and emergency stop facilities. Due to the varied nature of site installations this cannot be provided by Donaldson but instead is the responsibility of the customer.



Always isolate power before opening the controller.

Each Unicell dust collector is supplied with a C-Controller to operate the reverse jet cleaning system.

C10: 2-way controller

C20 and C40: 4-way controller

C50 and C75: 5-way controller

C30, C60 and C90: 6-way controller



For Controller connections and set-up, refer to Controller manual.

(ΔP connections)

On collectors fitted with a ΔP Controller, the cleanside and dirty side tapping points require connecting as shown in Figure 12, using the ΔP connection kit supplied.

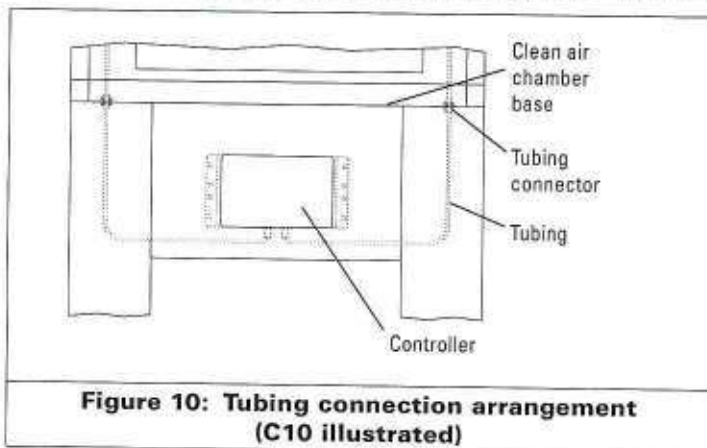

Figure 10: Tubing connection arrangement (C10 illustrated)

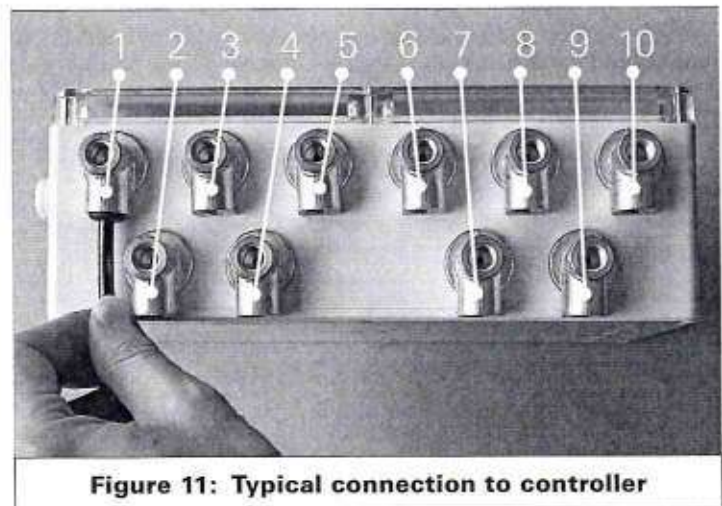

Figure 11: Typical connection to controller

Overload protection

All feeder circuits should be adequately protected with suitably-rated fuses and contactors with integral overload protection.

Integral fan

When the collector is fitted with a fan it should be wired to the fan terminal box located on the side of the collector (see Fig. 1). These terminals will need to be wired to a suitable control panel for the type of fan motor supplied. This control panel should be designed to comply with local legislation for electrical installations (refer also to 'Interlocks' and 'Overload protection').

Interlocks

Discharge equipment such as belt feeders, rotary valve or screw conveyor should be separately controlled but interlocked with the collector controller (see Fig. 13).

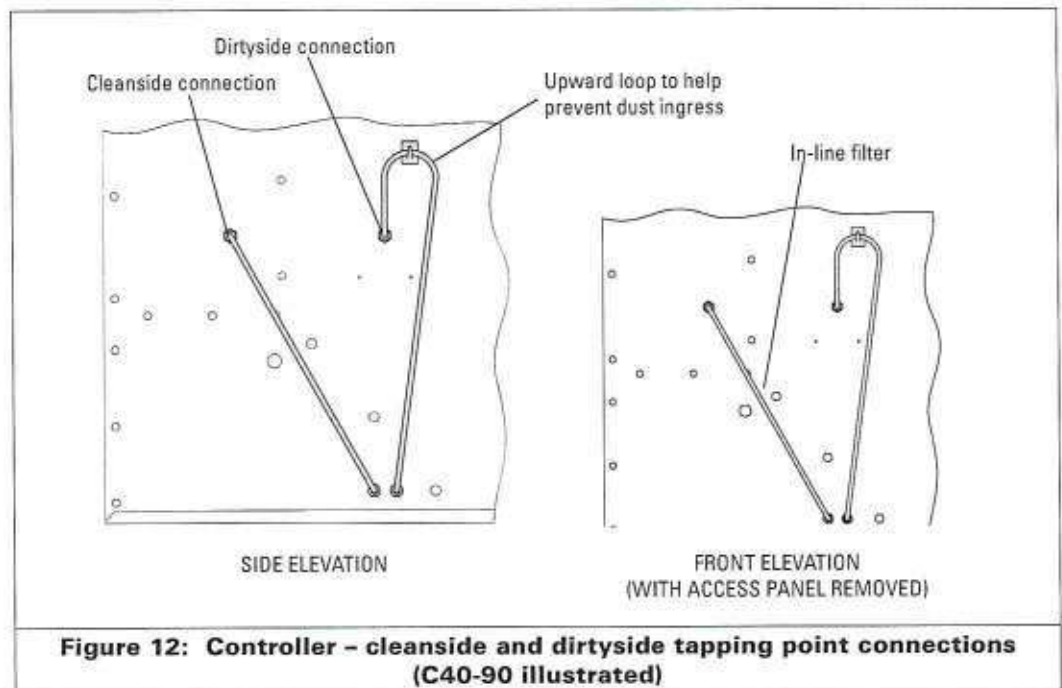

Figure 12: Controller - cleanside and dirtyside tapping point connections (C40-90 illustrated)

The design of the electrical circuitry controlling equipment associated with the Unicell dust collector should be such that breakdown of any one of the associated pieces of equipment does not cause a complete blockage of the unit. For example, should the motor of the rotary valve fitted to the unit cease to function, the unit housing will gradually fill with dust until completely choked. Failure of the compressor could also cause a similar blockage.

It is therefore important that the starters of all ancillary equipment be interlocked to ensure:

1. Correct starting sequence;
2. Operation of a warning system, or alternatively stoppage of the entire installation in the event of a failure of any of the auxiliary motors;
3. Correct stopping sequence.

Such interlocks are illustrated in Figure 13 which also allows for the compressor etc. to operate without airflow through the collector, to facilitate clearance of the filter in the event of blockage due to failure of non-electrical equipment.



It may be necessary to provide a facility to shut down the equipment in the event of an explosion (where collectors are fitted with explosion relief panels). The signal should be taken from the explosion relief detection device.

EEx controls

When the dust collector is to be installed in a hazardous area where there is any risk of fire or explosion, the collector will be marked for the area(s) it can be safely used within (refer to collector serial nameplate). The collector may be fitted with either of the following control systems:

EExd solenoids and remote controller

When this option is fitted, the dust collector has its solenoid valves in an EExd IIb T6 enclosure mounted directly to the unit. A controller, housed in an IP66 box, is supplied loose. This must be installed in non-classified area and connected to the solenoid valves on the dust collector using suitable cabling (not supplied).

It is recommended that cable with a core size of 2.5 mm² is used.



The maximum length of cabling that can be used is 100m.

Instructions for setting up the controller are the same as those for the standard controller.

PT Controller

The PT Controller is a pneumatically operated device which operates the diaphragm valves in sequence, therefore the need for an electrical supply is eliminated.

The controller is supplied complete with air regulator and is normally bracketmounted directly to the unit.



A moisture separator having a filter of 50-70 mm pore size should be fitted in the compressed air supply line, upstream from the supplied regulator to prevent clogging.



For PT Controller connections and set-up, refer to Publication 2697.

Antistatic earthing

It is particularly important on collectors having antistatic features and/or explosion relief, that the earthing post (located adjacent to the symbol shown here) is properly connected to earth, using the brass screw provided, to prevent any static build-up (refer also to Fig. 1).



Collectors with dust containers will have two connection points, located on the collector and the base.

TABLE 2 - PREDICTED FLAME LENGTHS
(calculation based on VDI 3673)

Type:	C10	C20	C30	C40	C50	C60	C75	C90
Flame length:	10.1 m	9.6 m	10.8 m	15.25 m	15.2 m	15.1 m	15.7 m	15.6 m

Explosion relief



The explosion relief area is suitable for the collector volume only. Fitment of the collector to larger vessels will require additional explosion protection to be fitted to the vessel. This protection should ensure that pressures developed during an explosion are lower than the collector strength. Consult Donaldson for specific collector design pressures. Refer to Table 2 for predicted flame lengths during an explosion.

Secondary or absolute filter monitor

The optional secondary or absolute filter monitor is supplied fitted to the front of the collector.



For secondary or absolute filter monitor connections and set-up, refer to Publication 2920.

Installation check list

- Ensure the Unicell dust collector filter section is securely bolted to the base section and the fan section is securely bolted to the filter section.
- Ensure the base section is securely bolted to the floor and, where applicable, the dust container base panel is bolted in position.
- Ensure compressed air supply is installed correctly and free from leaks.
- Ensure electrical supply is installed correctly and complies to local legislation.
- Ensure earthing straps are fitted on collectors supplied with antistatic filter modules.

COMMISSIONING



It is a requirement of the Supply of Machinery (Safety) Regulations 1992 to provide adequate isolation and emergency stop facilities. Due to the varied nature of site installations this cannot be provided by Donaldson but instead is the responsibility of the customer.



When making your preliminary checks, or during the start-up sequence, particularly note that on collectors fitted with an explosion panel the cleaning system should not be operated on its own for longer than necessary as the positive pressure produced could weaken the Membrex membrane.

Commissioning check list

- Ensure the Unicell dust collector filter section is securely bolted to the base section, and the fan section is securely bolted to the filter section.
- Ensure the base section is securely bolted to the floor and, where applicable, the dust container base panel is bolted in position.
- Ensure all ducting is complete and all detachable panels are in position.
- On C40-90 collectors, check the fork lifting cover plates have been replaced and sealed.
- Ensure collectors fitted with antistatic filter modules and/or explosion relief are suitably earthed.
- Where fitted, ensure explosion relief panels are venting to a safe area.
- Ensure the door seal is intact, then close and secure the door.
- Ensure the controller is connected to the correct voltage and the pulse interval and duration settings are correct. For 24V DC ensure polarity is correct. It is essential that the controller is earthed for both AC and DC connections.

- On C10-30 standard collectors with dust container or rotary valve and C10-30 venting type collectors with rotary valve, check the tubing is fitted correctly between the controller and the connectors underneath the clean air chamber base.
- Ensure electric power is available.
- Ensure the compressed air manifold has sufficient protection for overpressure.
- Start the compressor and check the air supply is maintained at the recommended pressure.
- If applicable, start up the discharge equipment (e.g. screw conveyor, rotary valve, belt feeders etc.).
- Switch on the controller and check all valves operate in sequence by 'feeling' pulses in rubber hoses (look and listen for exhaust pulses). As each valve operates, the air pressure reading should drop to approximately 50% of the initial setting and then return to the initial value.
- Start up the main fan and check for correct rotation and that the full load current is not exceeded (refer to fan rotation label located on rear panel of fan section).
- Verify operation of the interlocks and audible warning system if fitted.

If any of the above check boxes are not ticked, then the reasons why should be investigated. (Refer to fault location table in 'Maintenance' section).

Start-up sequence

Having completed all the necessary checks, the equipment may be put into operation. A typical installation, as shown in Figure 13, should be started up as follows:

1. Start up compressed air supply.
2. Set the equipment being served, if applicable, in motion.
3. Switch on discharge equipment (if applicable).
4. Switch on controller.
5. Start main fan.

Shut-down sequence



At the end of any period of operation it is most important that all residual deposits are cleared from the filter modules, casing, discharge hopper and equipment being served. To achieve this, equipment should be shut down in the following order:

1. Stop main fan only, leaving controller and compressed air supply switched on to allow filter to be cleaned 'off-line'.



To enable off-line cleaning, refer to controller manual.



This procedure is not recommended where explosion panels are fitted, as damage could result to the Membrex membrane. In such cases consult with Donaldson.

2. After 10-15 minutes, switch off controller and compressor but leave discharge equipment running to ensure that it is emptied.
3. After another 5 minutes, switch off the discharge equipment if applicable.



Where the dust being handled has self-heating properties, it is important to remove any deposits in the dust container to reduce the risk of an explosion.

Adherence to the above procedure will ensure that a Unicell dust collector installation is maintained at optimum efficiency.

OPERATION

Principle of operation

Dust-laden air is ducted into the chamber containing the filter modules, where it impinges on all their outer surfaces. A layer of dust builds up on the outside of the modules as the air itself passes through the media (see Fig. 14a). The clean air emerges from the outlet header of each filter module into the cleaned air chamber and from there it is discharged, normally via the fan, to atmosphere.

At regular intervals, governed by the controller, each filter module in turn receives a short burst of compressed air from its respective jet tube (see Fig. 14b). The jet tube has a series of small-diameter jet orifices positioned adjacent to the outlet header of each module (see Figs. 14 and 18). These orifices are of an optimum size and distance from the filter module, ensuring that a large volume of air is induced by each injection of compressed air. This causes a brief, powerful reversal of airflow through the filter module, effectively dislodging the dust layer which then falls into the discharge hopper.

In this way the pressure drop across the whole collector is kept at a virtually constant level, enabling the Unicell dust collector to operate continuously, twentyfour hours a day.

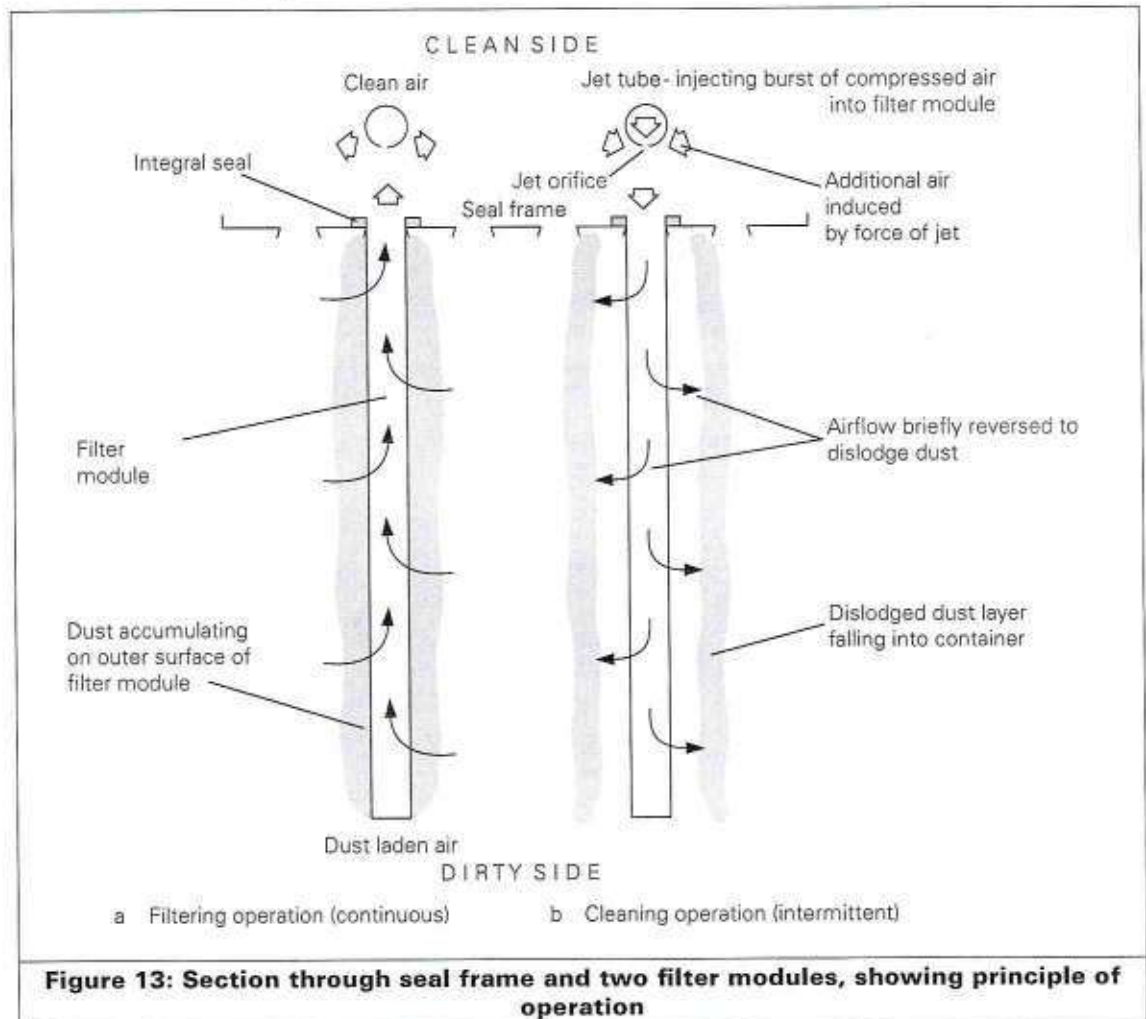

OPERATION

Dust disposal



For safe handling of the dust container an assessment must be made to satisfy the requirements of the European Directive 90/269/EEC on manual handling.



Dust containers may require regular emptying. If the dust being handled is explosive, then care should be taken to ensure that dust spillage is kept to a minimum to avoid the creation of potentially explosive atmospheres and secondary hazards.

Dust containers should be securely replaced and resealed prior to collector restart. This is a good time to check the dust container for damage, which may lead to a dust leak or flame emission in the rare instance of an internal explosion.

Standard dust container:

1. Release the container by raising the sealer gear handle.
2. Remove and empty the container.
3. Replace container by sliding it back into position.
4. Reseal the container by lowering the sealer gear handle.

Dust container with pressure balance:

1. Release the container by raising the sealer gear handle.
2. Slide the container out.
3. The polythene bag liner can be sealed in a manner to suit the toxicity of the dust and then removed.
4. Fit a new polythene bag into the dust container and slide the container back into position.
5. Reseal the container by lowering the sealer gear handle.

MAINTENANCE



A platform should be used when carrying out maintenance where the position of the technician's feet is greater or equal to 2 metres above ground level.



Before any work is carried out, ensure the equipment is adequately isolated from the electrical supply.



Ensure the pneumatic system is fully isolated and depressurised before any work is carried out.



For ancillary equipment not manufactured by Donaldson, refer to manufacturer's instructions.



If it is unavoidable to work on the equipment while an explosive atmosphere is present, care should be taken to avoid introducing ignition sources not present during expected operation. Non-sparking tools should be used.



Access to the dirty air chamber of the equipment may create risks and hazards that under normal circumstances are not present and as such this work must be carried out by competent personnel. These risks include inhalation of dust and potential explosion hazards.



In order to maintain the original collector specification and to ensure the same level of safety, only genuine spare parts should be fitted.



Every care has been taken to avoid the risk of ignition of a potentially flammable atmosphere. The measures taken to avoid ignition should not be altered since this may result in unsafe operation. Particular care should be taken during maintenance and component replacement to ensure the same level of safety is maintained. When replacing fan impellers, avoid any rubbing of components (to prevent mechanical sparks).



Care should be taken during cleaning and maintenance to avoid creating static discharges that have the potential to ignite a flammable atmosphere.

Routine inspection

To maintain the optimum performance of any Unicell dust collector, a routine inspection should be made to minimise down-time in the event of equipment malfunction, particularly on continuous performance applications, and to ensure the equipment is maintained to its original supply condition.

Any abnormal change in pressure absorbed across the filter modules indicates a change in operating conditions and a fault to be rectified. For example, a prolonged stoppage of compressed air will cause an excessive build-up of dust on the modules, resulting in a greatly increased pressure drop.

After the fault has been rectified, resumption of compressed air cleaning will usually return the collector to normal efficiency. However, it is advisable to operate the controller in still-air conditions for a short period to dislodge any accumulated dust before putting the collector into operation.

Unit resistance can be checked by connecting a U-tube manometer or differential type pressure gauge to tapping points on the unit casing (see Fig. 1). This will give a continuous indication of the state of the unit. Once running, the operating resistance

will be relatively stable, the actual value depending on the air volume and the characteristics of the dust being handled.

It is recommended to periodically inspect the general casing integrity and support structures.

It is recommended that door fastener threads are lubricated at regular intervals (applicable to units fitted with explosion relief).



Do not operate above recommended compressed air pressure. Excessive pressure will reduce the working life of components.



Unicell collectors fitted with explosion relief should be inspected weekly to ensure the bursting panels are intact and clear of obstruction. During winter, particular care must be taken to prevent build-up of snow or ice on explosion panels.

Servicing schedule

A record of all pressure checks should be kept in a log book to aid the speedy diagnosis of faulty operation.

Weekly

Open the valve at the bottom of the moisture separator bowl, if fitted, and allow the collected water to drain off, then close the valve.

Connect a manometer to tapping points (refer to Routine inspection) and measure the pressure drop across the unit.

Monthly

Check operation of solenoid and diaphragm valves.



It may be necessary to check the operation of the valves while the system is pressurised. Care should be taken to avoid injury.

If it is found necessary to replace a diaphragm, use the following procedure (refer also to Fig. 15):

Use service kit available from Donaldson.

1. Switch off fan and compressed air supply.
2. On C10-30 collectors open filter section access door, or on C40-90 collectors remove cleaning system access panel.
3. Remove 6 mm diameter nylon tube (A) by pulling out from valve.
4. Remove the hexagon head set screws and shakeproof washers securing the valve bonnet (B).
5. The diaphragm and spring (if fitted) can now be replaced, first ensuring the 'bleed' hole pin is not blocked.

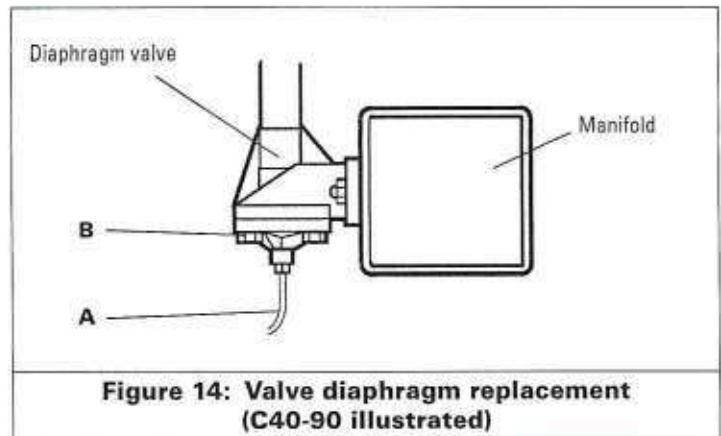

6. Ensure the diaphragm fits over 'bleed' hole pin and the nylon sealing washer is inside throat of valve.
7. Position spring (if fitted) inside bonnet recess.
8. Refit bonnet ensuring spring (if fitted) locates over diaphragm disc shoulder and bonnet locates over 'bleed' hole pin.
9. Refit and tighten the hexagonal head set screws and shakeproof washers.
10. Push-fit 6 mm diameter nylon tube back into valve.
11. The collector is now ready to restart.

Annually

1. Moisture separator (if fitted) – Isolate the compressed air supply; remove and clean the filter element.
2. Air manifold – Having isolated the compressed air supply, remove the drain plug and air inlet connections and clean out any accumulated sludge and inspect to any current local legislation.



It may be necessary to remove a diaphragm valve for internal inspection purposes.

3. Doors – Check the dust seals on all access doors for damage or ageing and ensure they are properly seated to prevent entry of water. This is particularly important where the collector is located outside or in a wet atmosphere.



Faulty seals must be replaced.

4. Filter modules – (On C40-90 collectors, cover the base with some suitable material before removing the modules to avoid any dust falling into the valve exhaust port.) Remove the jet tubes, then remove each filter module and check the general condition of the media and integral header seal. Clean the outside of each module using a vacuum cleaner. If the dust is of an abrasive nature it is advisable to examine the modules more frequently.



Filter modules showing excessive wear must be replaced.



On C40-90 collectors, any dust falling into the valve exhaust port should be removed before restarting the collector.

5. Jet Tubes – Check the jet tubes are clean and the jet orifices are clear.
6. Flameproof maintenance – It is important that all flameproof enclosures, motors and cable glands are inspected for corrosion and tightness on an annual basis.



In particularly aggressive environments, this period should be more frequent.

7. Antistatic earthing (if fitted) – Check collector earthing continuity.
8. Explosion risks – Check measures taken to avoid ignition sources are still in place.

Fan assembly removal/replacement

The following procedure is based on removal from left-hand side of collector.



Isolate electric power supply.

1. Disconnect electrical cables from the terminal box.
2. Remove lifting brackets.
3. Remove top plate (to gain access to the top bolts for the outlet baffle, remove outlet grille or back panel).
4. Remove the left-hand panel of the acoustic diffuser.
5. Remove internal baffles within the acoustic diffuser.
6. Remove fan section front panel or, on collectors with secondary/absolute filter, open fan section door and remove secondary/absolute filter element.
7. From the front of the collector, inside the fan section, remove the bolts locating the fan assembly to the fan division panel.
8. Remove the bolts locating the fan motor pedestal to the fan support channels.
9. The fan assembly can now be removed using a suitable lifting arrangement.



If changing fan assembly for a different type, e.g. K5 to K7, ensure the associated fan mounting plate and fan support channels are used. If required, any necessary electrical items should be resized.

Renewing motor on fan assembly:

1. Remove fan inlet plate to reveal the impeller.
2. Undo the grub screw and remove the impeller.
3. Remove fasteners holding the motor to the pedestal.
4. The motor can now be removed using suitable lifting equipment.
5. Position the new motor on the pedestal and slide impeller back onto the motor shaft, ensuring the key is located in keyway.
6. Replace all fasteners, including the grub screw on the impeller.
7. Replace the fan inlet plate.

Replacing the fan assembly:



Before replacing panels, apply 5 mm bead of sealing compound along each side of holes.



If the equipment has been supplied for use in a potentially explosive atmosphere, then a check should be made to ensure earthing continuity after replacing each panel.

1. Lift fan assembly into position.
2. Loosely replace bolts to locate the fan motor pedestal to the fan support channels.
3. Bolt the fan assembly to the fan division panel.
4. Ensure the fan assembly is correctly positioned, then tighten bolts.
5. Replace fan section front panel or, on collectors with secondary/absolute filter, replace secondary/absolute filter element and close fan section door.
6. Connect electrical cable to motor.
7. Replace internal baffles.
8. Replace left-hand panel of the acoustic diffuser.
9. Feed motor cable through left-hand panel and reconnect electrical cables to terminal box.
10. Replace top plate and outlet grille or back panel.
11. Replace lifting brackets.
12. Switch on electric power.
13. Ensure correct fan rotation (refer to fan rotation label located on rear panel of fan section).

Secondary or absolute filter replacement

(Refer also to Figures 16 and 17)

1. Open fan section door.
2. On C10-30 collectors, loosen filter element clamp nuts and remove channel; on C40-90 collectors, release tension latches and remove clamping frame(s).
3. Remove used element, place it directly into a plastic bag and then seal the bag.
4. Place the new element in position, with the element seal against the secondary/absolute filter seal frame.
5. On C10-30 collectors, replace filter element clamp channel and clamp nuts; on C40-90 collectors, replace clamping frame(s) and secure tension latches.
6. Close fan section door.

If in doubt regarding the safe disposal of the used element, consult your Environmental Health Officer.

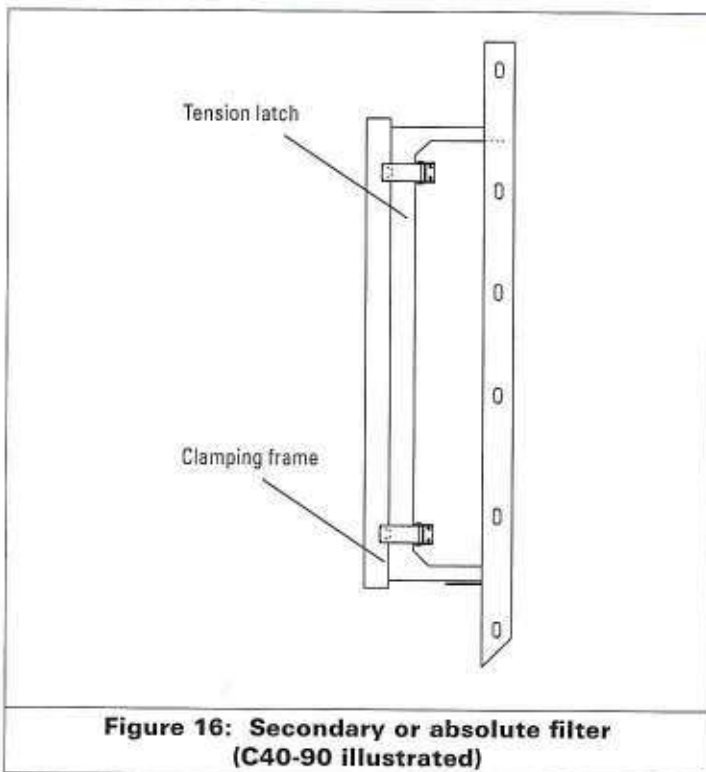
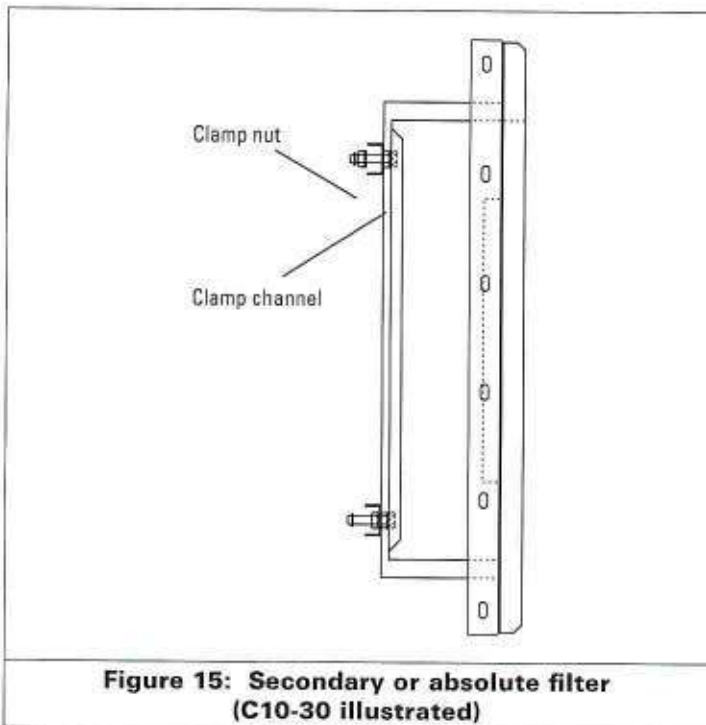

MAINTENANCE

Symptom	Possible cause	Action
Part loss of suction (excessive pressure differential)	Compressed air malfunction	If compressor stopped, rectify compressor fault; check interlocks; check motor and supply; check drive.
		If compressor OK, check pulses at manifold pressure gauge.
		Clean filters; dismantle and clean moisture separator.
		Check for excessive water or oil in compressed air supply, and possible accumulation in manifold.
	No pulses of air to valves.	Refer to controller manual supplied with the dust collector.
	Unit blocked	Check emptying device or equipment being served is working. Check starter overloads, fuses and interlocks.
Run unit clear*, then remove each module in turn and vacuum-clean all its outer surfaces. Renew any modules that are damaged.		
Motor speed low	Check line voltage, phases, fan motor connections. For Star/Delta applications, check motor in Delta.	
Incorrect fan motor rotation	Check electrical connections and transpose if necessary.	
Total loss of suction	Fan motor stopped	Check motor supply overloads, fuses and interlocks (if fitted).
		Check motor connections and transpose if necessary.
	Unit blocked	Check emptying device or discharge equipment is working. Check starter overloads, fuses and interlocks.
		Run unit clear*, then remove each module in turn and vacuum-clean all its outer surfaces. Renew any modules that are damaged.
	Ducting blocked	Check throughout and clear.
Visible effluent in clean air outlet	Damaged filter module	Damaged modules can be identified by dust being present in clean air chamber. Withdraw filter module and renew.

* To run unit clear, switch off main fan only and allow the controller to perform several complete cleaning cycles before switching off compressor etc.



This procedure is not recommended where explosion panels are fitted, as this could damage the Membrex membrane. In such cases consult Donaldson.

SPECIFICATION

Description and range

The Unicell is an automatic reverse-jet cleaned type of dust collector, designed to handle large quantities of dust-laden air, and is capable of continuous operation over extended periods. This reverse-jet cleaning system, which functions during the normal course of operation, not only serves to maintain optimum filtering efficiency at all times, but enables the collector to operate at a constant rating— in that it maintains a uniform pressure drop across the collector.

The basis of the Unicell is a filter section comprising a group of filter modules mounted on a sealed frame. The modules are fitted side by side and the individual sealing arrangement effectively separates the dirty (inlet) side of the collector from the clean (outlet) side, as shown in Figure 14. Removal of filter modules is always carried out from the cleanside of the collector.

The Unicell dust collector is available in a range of sizes (see Table 4), all available with or without fan and 80 litre dust container, rotary valve hopper or upstand for aperture mounting. An acoustic diffuser is fitted as standard on collectors with fan. For further details refer to Publication 2710.

A secondary filter can be fitted to Unicell collectors handling hazardous dusts, enabling filtered air to be recirculated safely back into the working area. It also acts a fail-safe device should the main filter modules become damaged. For special applications absolute (HEPA) filters are available (details on request). With certain dusts the filtered air must not be recirculated – if in doubt refer to Donaldson or the appropriate Health and Safety authorities. Each secondary filter panel is inserted through an access door in the fan section and sealed tightly in position by the locating mechanism. A secondary or absolute filter monitor can be supplied to measure the pressure drop across the filter which will indicate the filter condition and when maintenance is required.

Equipment is available suitable for use in a potentially explosive atmosphere (Directive 2014/34/EC) satisfying the requirements for group II category 2G or 2D and 3G or 3D T135°C.

Construction

The unit casing is constructed of mild steel panels which permit operation at partial vacuums down to -500 mm water gauge.

A large hinged inspection door gives access to the clean air chamber for removal of the jet tubes and filter modules when servicing and also, on C10-30 collectors, access to the control equipment, consisting of the air distribution manifold and diaphragm valves. On C40-90 collectors the control equipment is mounted immediately below the clean air chamber and is accessed via a removable panel.

For collectors fitted with optional secondary or absolute filters, a hinged door is provided on the fan section.

A lift-off inspection door is also provided in rotary valve type hoppers.

Filter modules (Figs. 1, 14 and 18)

Each removable filter module is manufactured from a spun-bonded polyester filter media with polyurethane end mouldings. The header moulding contains an integral seal.

Antistatic filter modules are available, secured with quick release handles to a stainless steel seal frame, as an option for installations where the dust is potentially explosive or improved dust flow is required.

Seal frame (Figs. 1, 14 and 18)

The seal frame is a rigid, rectangular structure of sheet steel, slotted to accept the filter modules. The modules are inserted from the cleanside of the collector and each one is individually clamped by means of a steel angle frame and secured by two clamps (quick release handles), therefore eliminating the requirement of any tools for this operation.

An earthing post is fitted to collectors with antistatic filter modules for connection to earth (see Fig. 1).

Jet tubes (Figs. 1, 14 and 18)

Positioned in the cleanside of the collector is a series of full-length jet tubes having small-diameter jet orifices located adjacent to the outlet header of each filter module. The 'open' end of each tube is connected to a compressed air valve; the closed end is flattened and crimped, and is secured by a bolt and nut.

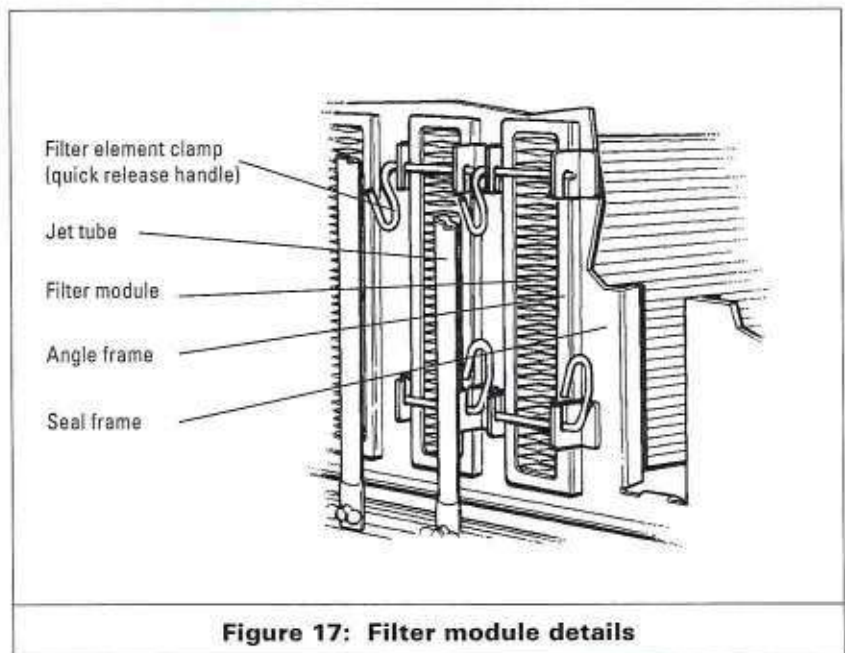

TABLE 4 - UNICELL DUST COLLECTOR RANGE

Type	Filtration area	Number of modules	Designation codes	
C10	10 m ²	2	C =	Unicell collector range
C20	20 m ²	4	10, 20, 30 etc. =	Size (filtration area in m ²)
C30	30 m ²	6	-3 =	Collector with dust container (number represents dust container size)
C40	40 m ²	8	R =	Collector with rotary valve
C50	50 m ²	10	H =	Hopper type collector
C60	60 m ²	12	V =	Venting type collector (unit supplied for external fan fitment)
C75	75 m ²	15	K5, K10 etc. =	Fan size, if fitted
C90	90 m ²	18	e.g. C20-3 K7; C50 H K10; C75 V; C90 VR	

Weighted sound pressure levels
(with acoustic diffuser fitted)**

K3 (1.5 kW)	K5 (2.2 kW)	K7 (3.0 kW)	G8 (5.5 kW)	K10 (5.5 kW)	K11 (7.5 kW)	K15 (11.0 kW)	K18 (15.0 kW)	K21 (18.5 kW)
66 dB(A)	72 dB(A)	73 dB(A)	75 dB(A)	74 dB(A)	76 dB(A) †	79 dB(A)	81 dB(A)	82 dB(A)

** All readings were taken in normal industrial areas, i.e. semi-reverberant surroundings, with local equipment silent.
Measurements were taken at maximum air flow conditions at 1.0 metre radius from the equipment housing and 1.6 metres above base level, using a precision sound level meter and octave filter. Noise levels of installed equipment may vary due to site conditions. = † Measured data

Temperature range:	-10° to +60°C (For applications outside this range refer to Donaldson)
Pressure range:	-500 mm W.G. (For positive pressures refer to Donaldson)
	Collectors with fan: as fan performance curves from shut-off to ambient pressure (refer to Publication 2710)
Maximum fan impeller speed:	3000 RPM (50Hz) or 3600 RPM (60Hz)

Valves (Figs. 1 and 19)

The compressed air is supplied to each jet tube via a diaphragm valve, the opening and closing of which is controlled by a solenoid-operated pilot valve connected to the diaphragm vent by a flexible nylon tube. The solenoid valves are energised sequentially by electrical pulses generated by the controller.

Compressed air distribution manifold (Fig. 1)

The manifold is fabricated from 150sq x 6 mm thick steel tube, with welded ends. Holes are provided for diaphragm valves, drain plug, pressure relief valve and air inlet moisture separator connections. (Moisture separator and pressure relief valve are not supplied as standard with the collector).

The manifold supplied with the Unicell dust collector has been independently approved to operate under the conditions as specified in Table 5.

Controller



For C-Controller specifications, refer to C-Controller manual.



For PT Controller specifications, refer to Publication 2697.

Fan (Fig. 1)

The fan (not applicable to venting type units) is housed within an acoustic diffuser located above the filter section.

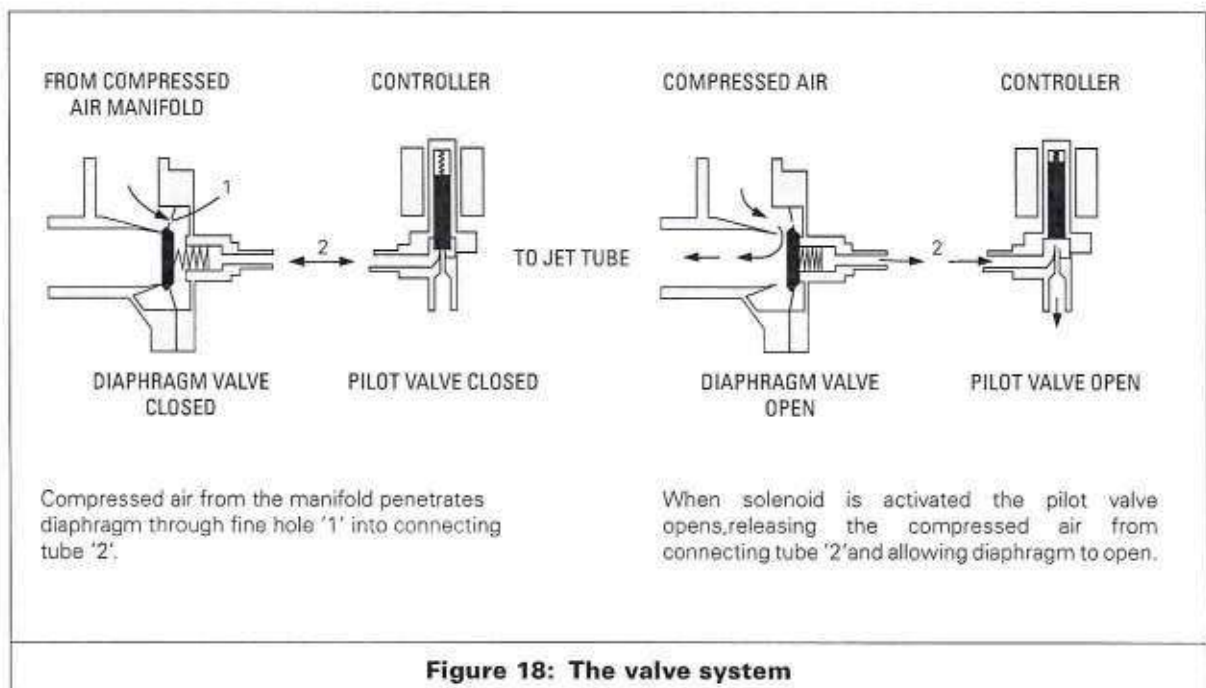

TABLE 5 - COMPRESSED AIR MANIFOLD DESIGN DETAILS

Design pressure:	6.9 bar (100 psig)
Maximum operating pressure, PS:	6.2 bar (90 psig)
Test pressure:	10.35 bar (150 psig)
Design temperature:	-30° to +60°C
Maximum rating of pressure relief device:	17 dm ³ /s at 6.9 bar (not supplied as standard)
Manifold volume:	11.21 litres (C10 and C20) 17.85 litres (C30, C40, C50, C60, C75 and C90)
Product of pressure and capacity:	69.50 bar litres (C10 and C20) 110.67 bar litres (C30, C40, C50, C60, C75 and C90)
Material used for manifold construction:	Structural hollow section
Minimum metal thickness before manifold requires special inspection:	To improve corrosion resistance the manifold is painted externally and internally using cathodic electrocoat. 5.5 mm

TABLE 6 - COMPRESSED AIR REQUIREMENTS

Type	Working compressed air pressure ^a		Atmospheric air volume - F.A.D. ^b at 12 sec. intervals ^c		Pulse duration	Minimum pipe diameter ^d
C10	3.7 bar	55 psig	7.3 m ³ /h	4.3 cfm	100 millisec.	½" NB (12)
C20	3.7 bar	55 psig	7.3 m ³ /h	4.3 cfm	100 millisec.	½" NB (12)
C30	3.7 bar	55 psig	9.6 m ³ /h	5.7 cfm	100 millisec.	½" NB (12)
C40	4.5 bar	65 psig	13.7 m ³ /h	8.1 cfm	100 millisec.	½" NB (12)
C50	4.5 bar	65 psig	13.7 m ³ /h	8.1 cfm	100 millisec.	½" NB (12)
C60	4.5 bar	65 psig	13.7 m ³ /h	8.1 cfm	100 millisec.	½" NB (12)
C75	5.2 bar	75 psig	15.6 m ³ /h	9.2 cfm	100 millisec.	½" NB (12)
C90	5.2 bar	75 psig	15.6 m ³ /h	9.2 cfm	100 millisec.	½" NB (12)

^a Normal operating pressure.

^b Recommended atmospheric air volume of clean, dry compressed air.

^c Recommended initial settings; these may be varied with experience.

^d Sizes suitable for runs of pipe up to 30 m (100ft) in length; for longer runs consult with Donaldson.

For connection details please refer to Publication 2710.

$$1 \text{ bar} = 10^5 \text{ Pa}$$

Supplementary Information

For Installation, Operation and Maintenance Manuals

This document is supplementary to the Installation, Operation and Maintenance Manual supplied with the unit and provides additional information for units that are required to meet the ATEX (2014/34/EU) Directive – "Equipment and protective systems intended for use in Potentially Explosive Atmospheres".

Please read this information and the manual carefully before commencing any work. Product reliability, warranty and safe operation may be compromised by not following the guidance given in these documents.

- 1 The dust collector should be used only when it is in a technically acceptable condition. Regular maintenance, as set out in this manual, is required to minimise technical failure. Third party supplied components (for example motors) should be maintained according to the manufacturer's instructions.
- 2 In order to maintain the original collector specification and to ensure the same level of safety, only genuine spare parts should be fitted.
- 3 You should ensure any persons carrying out work on the supplied equipment follow any relevant recognised standards/codes and are competent to do so. Areas requiring a competent person include:
 - Maintenance on any component identified as a potential ignition source.
 - Lifting and erection.
 - Electrical installation, inspection and maintenance work.
 - Pneumatic installation, inspection and maintenance work.
 - Any access to internal classified Potentially Explosive Atmospheres where the risks due to explosion and dust contact are reduced to a safe level.During assembly/installation or dismantling of equipment, potential ignition sources may occur that were not considered in the risk assessment of the unit in operation (for example, grinding, welding sparks, etc.)
- 4 You should use the dust collector in full accordance with the conditions set out in the Order Acknowledgment and relevant Scope of Delivery. Failure to do so may compromise product reliability, warranty and safety. The Scope of Delivery is an integral part of the manual.
- 5 Other items of equipment, not supplied under the Scope of Delivery from Donaldson, should be installed, operated and maintained according to the documentation supplied with the respective equipment.

- 6 Before any work is carried out, ensure the equipment is adequately isolated.
- 7 Where necessary for safety, the dust collector is fitted with fixed guards. Removal of these guards and any subsequent work should only be carried out after adequate precaution is taken to ensure it is safe to do so. All guards should be refitted before re-energising.
- 8 Ensure the pneumatic system is fully isolated and depressurised before any work is carried out.
- 9 Access to the dirty air chamber of the equipment may create risks and hazards that under normal circumstances are not present and as such this work must be carried out by competent personnel. These risks include inhalation of dust and potential explosion hazards.
- 10 The equipment supplied is suitable for working within a potentially explosive atmosphere (as defined by Directive 2014/34/EC) according to the categories and conditions marked on the collector serial nameplate. You should ensure the equipment supplied by others is also suitable. If no marking is given on the serial nameplate then the supplied equipment is not suitable for use in potentially explosive atmospheres.
- 11 Care should be taken to ensure that any potentially explosive atmosphere is not present when performing operations that increase the risk of ignition (opening of controller for adjustment or electrical repair for example). Ensure the installation is always returned to its original state.
- 12 If it is unavoidable to work on the equipment while a potentially explosive atmosphere is present, care should be taken to avoid introducing ignition sources not present during the expected operation. Non-sparking tools should be used.
- 13 Where equipment is installed in a potentially explosive atmosphere, care should be taken not to locate the collector where external ignition sources can be introduced, for example stray electric currents, lightning, electromagnetic waves, ionising radiation, ultrasonic waves.
- 14 Where the dust being processed can ignite due to exothermic reaction, including self ignition, the collector **MUST** be fitted with a suitable explosion protection method (venting for example). The risk of ignition can be minimised by avoiding the accumulation of dust layers with regular cleaning.
- 15 Every care has been taken to avoid the risk of ignition of a potentially flammable atmosphere. The measures taken to avoid ignition should not be altered since this may result in unsafe operation. Particular care should be taken during maintenance and component replacement to ensure the same level of safety is maintained. When replacing fan impellers, avoid any rubbing of components (to prevent mechanical sparks).
- 16 This dust collector may be fitted with explosion protection in the form of a vent panel. Precautions, as set out in the Scope of Delivery, are used to minimise the risk of ignition of any dust clouds contained within the dust collector. The possibility of other ignition sources being introduced into the collector during periods where any dust cloud may be present should be minimised. Particular care should be taken to avoid introducing glowing particles via the collector inlet ducting.

- 17 The explosion relief assembly, where fitted, has been designed to provide adequate safety from an explosion initiated from within the collector, for the given dust explosion characteristics and collector arrangement as set out in the Scope of Delivery. You should ensure that explosions are not allowed to propagate into the dust collector (using suitable isolation devices) since pressures may be generated leading to unsafe equipment rupture.
- 18 Where applicable, equipment connected to the dust collector (for example, a cyclone) should be protected, using suitable isolation devices, against the transfer of flame and pressure if, in the event of an explosion initiating inside the dust collector, the connected equipment is not capable of safely withstanding these effects.
- 19 The explosion relief assembly, where fitted to the dust collector, is not suitable for use with dusts that are classified as poisonous, corrosive, irritant, carcinogenic, teratogenic or multigenic unless the dust released during the explosion venting process can be contained to a safe level.
- 20 Where applicable, care is required when siting the dust collector to ensure that the effects (flame, pressure, noise and fire) produced during and after the explosion venting process do not put at risk personnel and nearby plant.
- 21 In order to ensure the required venting efficiency is maintained, the explosion relief assembly, if fitted to the collector, should not be obstructed in any way.
- 22 Any modification carried out on the 'as supplied' equipment may reduce reliability and safety, and will nullify warranty; such actions fall outside the responsibility of the original supplier.
- 23 On a day to day basis there is minimal interaction between the operator and the collector, however dust containers may require regular emptying. If the dust being handled is explosive, then care should be taken to ensure that dust spillage is kept to a minimum to avoid the creation of potentially explosive atmospheres and secondary hazards.
Dust containers should securely replaced and resealed prior to collector restart. This is a good time to check the dust container for damage, which may lead to a dust leak or flame emission in the rare instance of an internal explosion.
- 24 Compressed air is recommended for collectors that operate using reverse jet cleaning. Alternative gases should be assessed before use to ensure that explosive atmospheres are not introduced during media cleaning.
- 25 It may be necessary to provide a facility to shut down the equipment in the event of an explosion (where collectors are fitted with explosion relief panels). The signal should be taken from the bursting panel detection device.
- 26 Care should be taken during cleaning and maintenance to avoid creating static discharges that have the potential to ignite a flammable atmosphere.
- 27 Earthing of the equipment is an integral safety feature. Regular checks should be made (annually) to ensure continuity.

- Africa** Donaldson Europe B.V.B.A.
Industrial Filtration Solutions
Research Parc Bldg No. 1303
Interleuvenlaan, 1
B-3001 Leuven
Belgium
IAF-africa@donaldson.com +32 16 38 39 70
- Austria** Donaldson Filtration Österreich GmbH
Guthell-Schoder Gasse 6-12
A-1100 Wien
Österreich
IAF-at@donaldson.com +43 16 16 52 91
- Belgium** Donaldson Europe B.V.B.A.
Industrial Filtration Solutions
Research Parc Bldg No. 1303
Interleuvenlaan, 1
B-3001 Leuven
België
IAF-be@donaldson.com +32 16 38 39 70
- Czech Republic** Donaldson Industrial CR s.r.o.
Královský vrch 1985
CZ-432 01 Kadaň
Czech Republic
IAF-cz@donaldson.com +420 474 610 700
- Denmark** Donaldson Scandinavia ApS
Lyngse Allé 3A
DK - 2970 Hørsholm
Danmark
IAF-dk@donaldson.com +45 45 57 00 77
- Finland** Donaldson Scandinavia ApS
Lyngse Allé 3A
DK - 2970 Hørsholm
Danmark
IAF-fi@donaldson.com +45 45 57 00 77
- France** Donaldson France s.a.s.
33 Rue des Vanesses
Zac Paris Nord II B.P. 51292 Villepinte
F-95958 Roissy
Charles de Gaulle Cedex
France
IAF-fr@donaldson.com +33 1 49 38 99 30
- Germany** Industrial Filtration Solutions
Industriestraße 11
D-48249 Dülmen
Deutschland
IAF-de@donaldson.com + 49 2594 781-41
- Hungary** Donaldson Filtration Magyarország Kft.
Záhony u. 7.
H-1031 Budapest
Magyarország
IAF-hu@donaldson.com +36 1 453 28 65/66
- Ireland** Donaldson Filtration (GB) Ltd.
Suite 31, The Hyde Building The Park
Carrickmines, Dublin 18
Ireland
IAF-ie@donaldson.com +353 1 525 22 49
- Italy** Donaldson Italia S.r.l.
Via Cesare Pavese, 5/7
20090 Opera (Milan)
Italia
IAF-it@donaldson.com +39 0 25 30 05 21
- Middle East** Donaldson Europe B.V.B.A.
Office 1905
Jebel Ali Free Zone
Dubai
United Arab Emirates
IAF-middle-east@donaldson.com +971 4 885 5311
- Netherlands** Donaldson Nederland B.V.
Transistorstraat 44 III
NL-1322 CG Almere
Nederland
IAF-nl@donaldson.com +31 36 548 08 40
- Norway** Donaldson Filtration Norway AS
Postboks 196
N-1501 Moss
Norge
IAF-no@donaldson.com +47 69 21 53 00
- Poland** Donaldson Polska Sp. z o.o.
ul. Sienna 64
PL-00-825 Warszawa
Polska
IAF-pl@donaldson.com +48 22 517 15 00
- Russia** Представительство AQOO Donaldson Nederland B.V.
Центр Международной Торговли
Офис 1004V, Краснопresnenskaja nab. 12
123610 Москва
Russia
IAF-ru@donaldson.com +7 499 136 00 13
- Slovakia** Donaldson Filtration Slovensko s.r.o.
Račianska 77
SK-831 02 Bratislava
Slovensko
IAF-sk@donaldson.com
- Spain** Donaldson Iberica, Soluciones en Filtración, S.L.
Colom, 391 - 3ªA
E-08223 Terrassa
España
IAF-es@donaldson.com +34 93 784 38 34
- Sweden** Donaldson Scandinavia
Industrigatan 68
S-261 35 Landskrona
Sverige
IAF-se@donaldson.com +46 418 457 550
- Switzerland** Donaldson Schweiz GmbH
Bruggacherstrasse 18
CH-8117 Fallanden
Schweiz
IAF-ch@donaldson.com +41 (0)44 302 07 15
- Turkey** Donaldson Filtre Sist. Tic. Ltd. Sti.
Barbaros Mahallesi Palladium Tower No.2 Kat:10
34746 Ataşehir / Istanbul
Türkiye
IAF-tr@donaldson.com +90 216 687 03 26
- United Kingdom** Donaldson Filtration (GB) Ltd.
Humberstone Lane Thurmaston
Leicester LE4 8HP
United Kingdom
IAF-uk@donaldson.com +44 116 269 6161
- Other countries** Donaldson Filtration (GB) Ltd.
Humberstone Lane Thurmaston
Leicester LE4 8HP
United Kingdom
IAF-export@donaldson.com +44 116 269 6161

Order online 

shop.Donaldson.com



INSTALLATION, OPERATION AND MAINTENANCE MANUAL

Controller
C300



INTRODUCTION

Congratulations with the purchase of the C300 Controller!

The C300 is equipped with the latest processor & data transfer technology to ensure easy, smart & functional operation.



Your controller is already set up with default settings and can be used as a plug and play device. Please contact our Donaldson trained personnel for optimal alignment of the cleaning system with your specific application.

Once connected to the power supply, the C300 controller operates automatically & independently.

TABLE OF CONTENTS

Overview product line	4
Overview	5
Safety recommendations	6
Device description	6
Installation	7
Before starting	11
Operation.....	12
Multiple valve boxes and valve control units	13
User interface	16
Glossary	20
Troubleshooting	23
Alarm identification table	25
Warning identification table	27
Declaration of Conformity	28

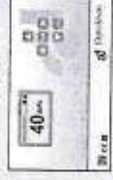
OVERVIEW PRODUCT LINE

	C100 	C200 	C300 
Voltage supply	110 VAC, 230 VAC (50/60Hz) or 24VDC	110 VAC, 230 VAC (50/60Hz) or 24VDC	110 VAC, 230 VAC (50/60Hz)
User interface	3 status LEDs	graphic display & buttons	sun-readable colour display & buttons real time data logging system
Delta-P sensor	No	Yes	Yes
Inputs			
digital	2 x fixed inputs: - interrupt - fan feedback (fan in operation signal)	<ul style="list-style-type: none"> • 2 x programmable inputs • 1 x bursting disc signal input (venting panel) 	<ul style="list-style-type: none"> • 5 x programmable inputs • 1 x bursting disc signal input (venting panel) • 1 x PTC input
analogue	-	1 x Delta-P input (4-20mA)	2 x programmable inputs
Outputs			
number of valve outputs	12 (**)	12 (**)	12 (**)
max. number of mounted valves to the controller's enclosure	10	10	10
digital	-	2 x programmable outputs	3 x programmable outputs
analogue	-	1 x Delta-P output (4-20mA)	1 x Delta-P output (4-20mA)
power output	-	1 x 24 VDC - 5W	1 x 24 VDC - 10W
Data logging/events logging	no	200 event log	<ul style="list-style-type: none"> • 500 event log with time/date indication • differential pressure history/log
Wireless parameter transfer (NFC)	yes	yes	yes

(**) When C-controller has less than 6 solenoid valves integrated to its enclosure, there will be only 6 valve outputs (C-controllers with no integrated solenoid valves have 12 valve outputs)

OVERVIEW

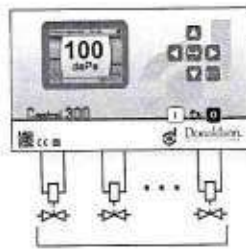

6 valve outputs or 12 valve outputs*

depending on number of valves mounted on the enclosure

*maximum of 10 valves can be integrated in the controller enclosure itself

6 valve outputs:

used in controllers with less than or equal to 6 valves mounted on the enclosure

12 valve outputs:

used in controllers with no valves and controllers with more than 6 valves mounted on the enclosure

Bus cable

5 wires bus cable with male and female connectors, RS485 interface

maximum 9 valve boxes



up to 12 valves mounted

Valve Box

A Valve Box is a valve control unit with integrated solenoid valves in its enclosure. A valve control unit acts as a small extension module used to control multiple pulse cleaning valves. The Valve Box is connected with a plug & play bus system to the main controller.

maximum 9 VCU's



up to 12 remote valves (max 22W/valve)

Valve Control Unit (VCU)

A Valve Control Unit is a small extension module used to control multiple pulse cleaning valves. In case of VCU, solenoid valves are integrated in the diaphragm valve. The VCU is connected with a plug & play bus system to the main controller.



Motor Control Unit (MCU)

Motor Control Unit is a small extension module/PCB to control the dust collector fan (integrated in C-Powerbox only).



C-Powerbox

An assembly of a C300 controller with an MCU and suitable motor starter for controlling the desired fan

SAFETY RECOMMENDATIONS



This filter control unit carries hazardous electrical voltage when connected to the mains. Improper installation of the connected electrical equipment may cause device failure, serious or even fatal injuries. In addition to general safety rules of industrial electrical installations, pay particular attention to the following points:

- All applicable laws, conditions, rules and regulations governing the installation of electrical equipment must be observed.
- All electrical work has to be done by a qualified electrician according to the national and local electric codes that apply (EN60204.1, IEC 364).
- It is a requirement of the Supply of Machinery (Safety) Regulations 1992 to provide adequate isolation and emergency stop facilities. Due to the varied nature of site installations this cannot be provided by Donaldson but instead is the responsibility of the customer.
- For installation in hazardous areas, all work must be carried out with the electrical supply isolated or only when the potentially explosive atmosphere is not present.
- The controller should not be used in an ATEX zone when it is not mounted with the correct ATEX category marking.

DEVICE DESCRIPTION

The C300 controller is used to control 24 V DC solenoid valves (max. 22Watt/valve) on dust collectors with compressed air cleaning.

The controller comes with solenoid valves mounted on its enclosure up to 10 valves or with 0 valves mounted version with 12 valve outputs to control maximum 12 remote solenoid valves (22Watt each).

Additionally, the C300 valve outputs can be extended by using VCU modules or C-Valve boxes. They are connected to the bus interface of the C300 controller in series with bus cables.

Optionally, the C300 can also control a fan motor when equipped with a Motor Control Unit (MCU). For this option, the controller is integrated in a power box (front door) that contains MCU PCB and Motor Starter for the controlled fan.

Once connected to the power supply, the C300 controller operates automatically and independently.



C300 stand-alone controller



C-Powerbox

INSTALLATION

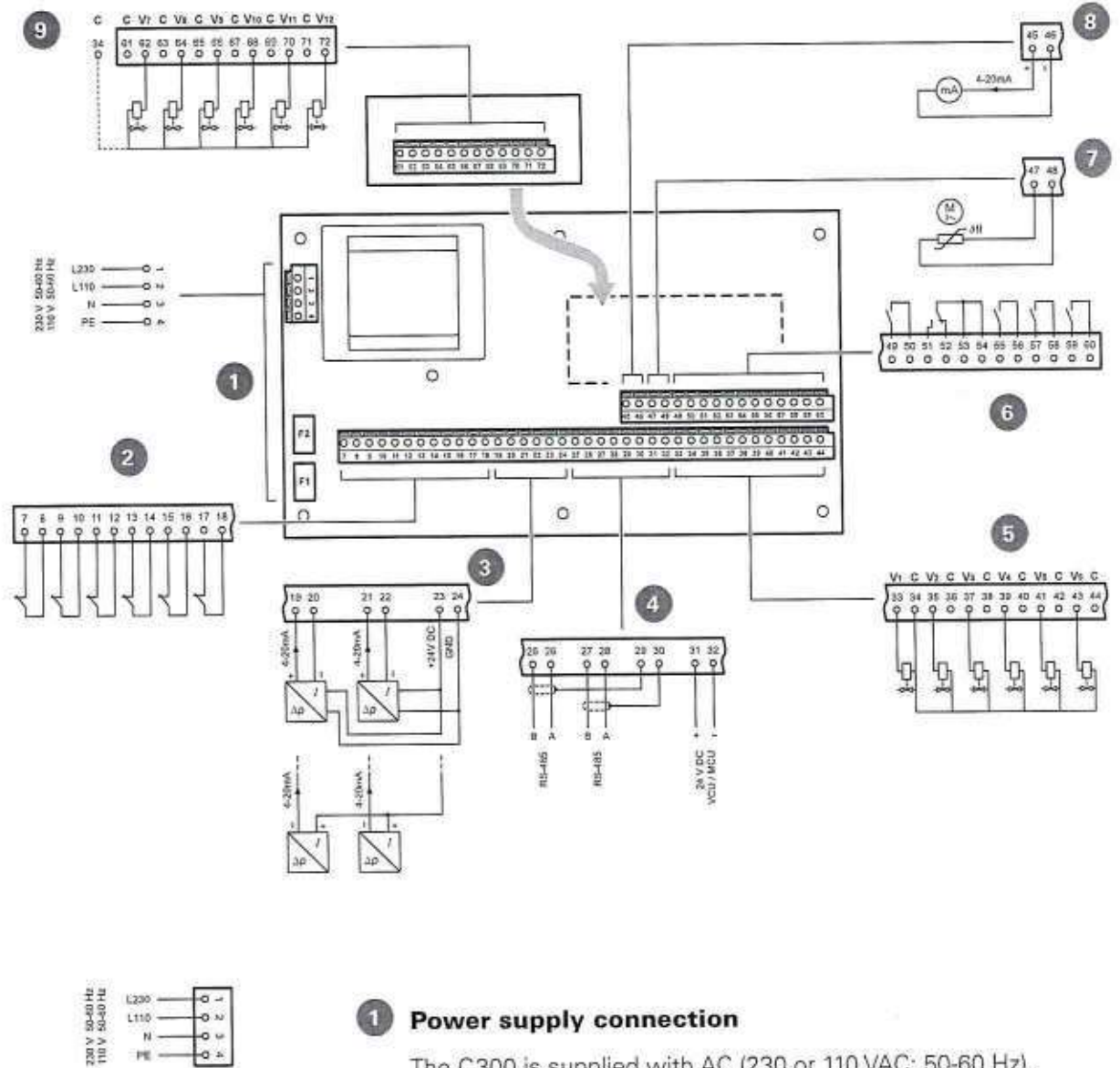

1 Power supply connection

The C300 is supplied with AC (230 or 110 VAC; 50-60 Hz).

Fuses

F1: T 0.2 A, 250 V, 5 x 20 mm (for the 230 VAC circuit)

F2: T 0.3 A, 250 V, 5 x 20 mm (for the 115 VAC circuit)



Wrong connection will destroy the control board. Do not use cables larger than 1,5 mm² to connect to power supply as this may damage the terminal block.

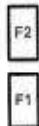
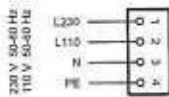

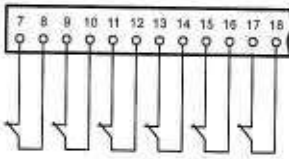

2 Digital input connection

Check the available selectable options in the 'Programmable Input Options' table in the Glossary section.

- 7, 8 input 1 function, chosen in the program menu
- 9, 10 input 2 function, chosen in the program menu
- 11, 12 input 3 function, chosen in the program menu
- 13, 14 input 4 function, chosen in the program menu
- 15, 16 input 5 function, chosen in the program menu
- 17, 18 fixed input for connection explosion panel



All inputs should be potential free normally closed contacts.



Disable the input function in the program menu when it is not used.

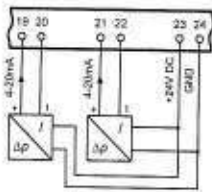

4-wire technology

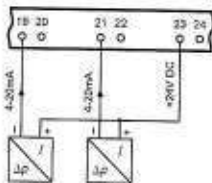

2-wire technology

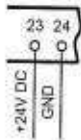

3 Analog inputs

- 19, 20, 23, 24 4-20 mA-input 1, 4-wire technology
- 19, 23 4-20 mA-input 1, 2-wire technology
- 21, 22, 23, 24 4-20 mA-input 2, 4-wire technology
- 21, 23 4-20 mA-input 2, 2-wire technology



See page 21 for specifications of the sensor for analog inputs.

DC power output supply 10W, 24V

- 23, 24 Used for 4-wire technology remote ΔP sensor or for other apparatus with maximum 10 Watt power consumption

4 Bus RS-485-Interface

connection of VCU and MCU module

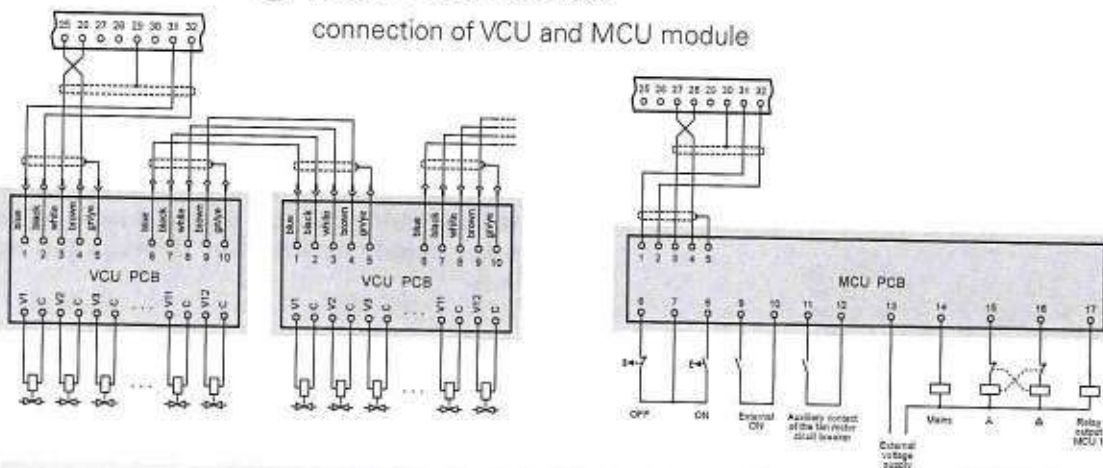

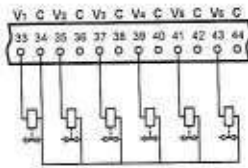

5 Solenoid valves 1 to 6

The solenoid valve 'C' terminals are internally connected (34-36... 44)

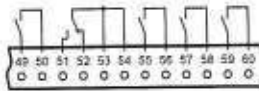

6 Relay outputs

Check the available selectable options in the 'Programmable Output Options' table in the Glossary section.

- 49, 50 Thermistor relay contact
- 51 (NO), 52 (NC), 53 (COM), 54 (COM) Fixed alarm output: during an alarm, the Normally Closed contacts are closed and the Normally Open contacts are open
- 55, 56 Output 1 function, chosen in the program menu
- 59, 60 Output 2 function, chosen in the program menu
- 57, 58 Output 3 function, chosen in the program menu



The programmable output contacts are normally open.

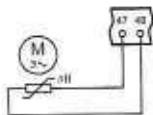

7 Thermistor input

Fixed thermistor input to guard motor temperature

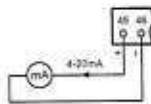

8 Analog output

45, 46 4-20 mA-output for Δp -remote indicator connection
It corresponds to 0 - 3500 Pa

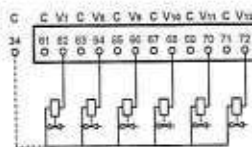

9 Solenoid valves 7 to 12

Additional board used in:

- C300 with more than 6 valves mounted on enclosure
- C300 with 0 valves mounted on enclosure

The solenoid valve 'C' terminals are internally connected (34, 61... 71)

 When using the 'External ON' option on the MCU board, it is a must to use shielded cable and connect the shielding to the dedicated cable shielding clamp.

 Do not use cables larger than 1,5 mm² to connect to power supply as this may damage the terminal block.

 When the online cleaning is set to ΔP cleaning mode, the ΔP hoses from the dirty air and clean air plenum should be connected to the controller. DAP / CAP hoses can be connected either side. The controller corrects negative pressure automatically.

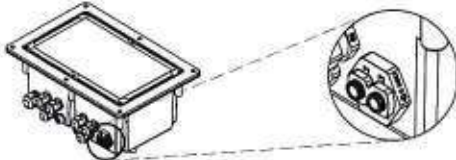

 The specifications of the sensor for analog inputs should correspond to the following ranges:

Manifold pressure	Analog pressure sensor	0 - 10 bar
Remote ΔP	Analog pressure sensor	0 - 10.000 Pa
Emission sensor	Analog emission sensor	0 - 100%

 Ensure correct connection of the pneumatic tubing (outer Ø 6 mm), see figure below.

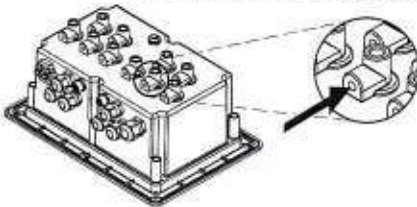

 Battery exchange, use CR 2032, 3V battery

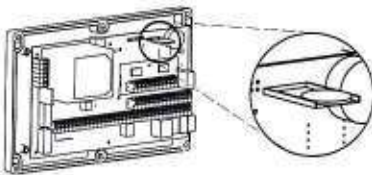

After replacing battery, set the correct date and time in the controller.

Access the settings with the customized PIN code (standard: 9999) and go in menu (set date) and (set time).

 Ensure correct connection sequence of the solenoid valves, **A** is the air ventilation plug.

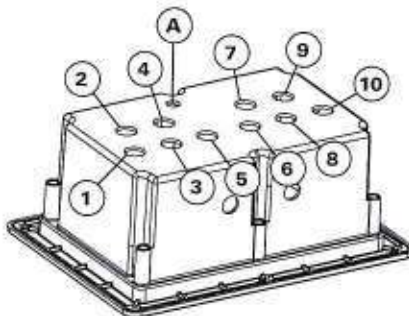

C300 enclosure

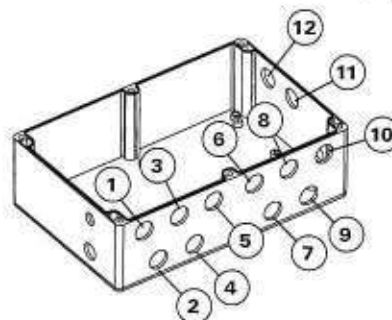



Valve box enclosure

BEFORE STARTING

Make sure to apply the Automatic Valve Detection procedure before using the controller in order to verify the number of valves connected to the system.

Automatic Valve Detection procedure:

1. Switch off the C300 controller
2. Connect all the Valve Boxes
See page 13 for connection information
3. Press down the  button of the C300 controller and hold.
4. Switch on the C300 controller while the  button is still pressed in.

Automatic valve detection will start and when done, the number of detected valves and Valve Boxes (=VCU) will be displayed.

Example:

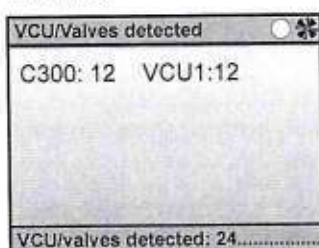

OPERATION

The controller is fully automatic & ensures the cleaning system is operated at regular intervals, to facilitate efficient cleaning of the filter elements. Moreover, it can control a fan motor independently by integrating the controller in a power box with motor starter and a Motor Control Unit (MCU).

The first time the controller is powered, up a complete system check is performed and at regular intervals the system performs diagnostic tests to ensure system & data integrity. If any abnormality is found, an alarm or warning message is triggered for your information.

Your controller is already set up with default settings and can be used as a plug and play device. Please contact our Donaldson trained personnel for optimal alignment of the cleaning system with your specific application.

Once connected to the power supply, the C 300 controller operates automatically & independently.

Under normal operation a dust coating is built up on the filter elements. This coating can enhance the filter's overall efficiency but it can also become damaging to the dust collector's performance. This will happen when the dust coating is allowed to build up to such an extent that it becomes a barrier to the air flow.

The controller is especially designed to control the cleaning system of a Donaldson dust collector. It fires the compressed air cleaning valves sequentially with a regular interval to partly remove the built up dust cake from the filter elements.

Furthermore, the C 300 is equipped with 5 programmable inputs, 3 programmable relay outputs, a fixed bursting disc sensor input, two 4-20 mA analog input for differential pressure or emission sensors, and a 4-20 mA ΔP output for interfacing with external systems. A 10 watt input is also available for the power supply of the ΔP analog sensor or any equipment with power below 10 watt.

MULTIPLE VALVE BOXES AND VALVE CONTROL UNITS

The C-controllers work with a serial-linked system allowing one single controller to operate up to 9 valve boxes or VCU's.

Each C-controller, Valve Box and VCU can have up to 12 valve outputs, this brings the maximum number of solenoid valves to be operated by one single controller up to 120 valves (= 10 x 12 valves).

Note: The C-controller can only house up maximum 10 valves in its enclosure. In that case, the maximum number of solenoid valves to be operated by the controller is 118 valves (= 10 valves + (9 x 12 valves))

Wiring of the boxes are done by a simple bus cable and in series.

Male connector of the bus cable fits in the female connector of the controller, female connector of the bus cable fits in the male connector of the valve box or VCU, see figure below. The connected valve boxes/VCU's, and their number of solenoid valves will automatically be detected by the controller when the Automatic Valve Detection procedure is applied. (check the "Before starting" section)

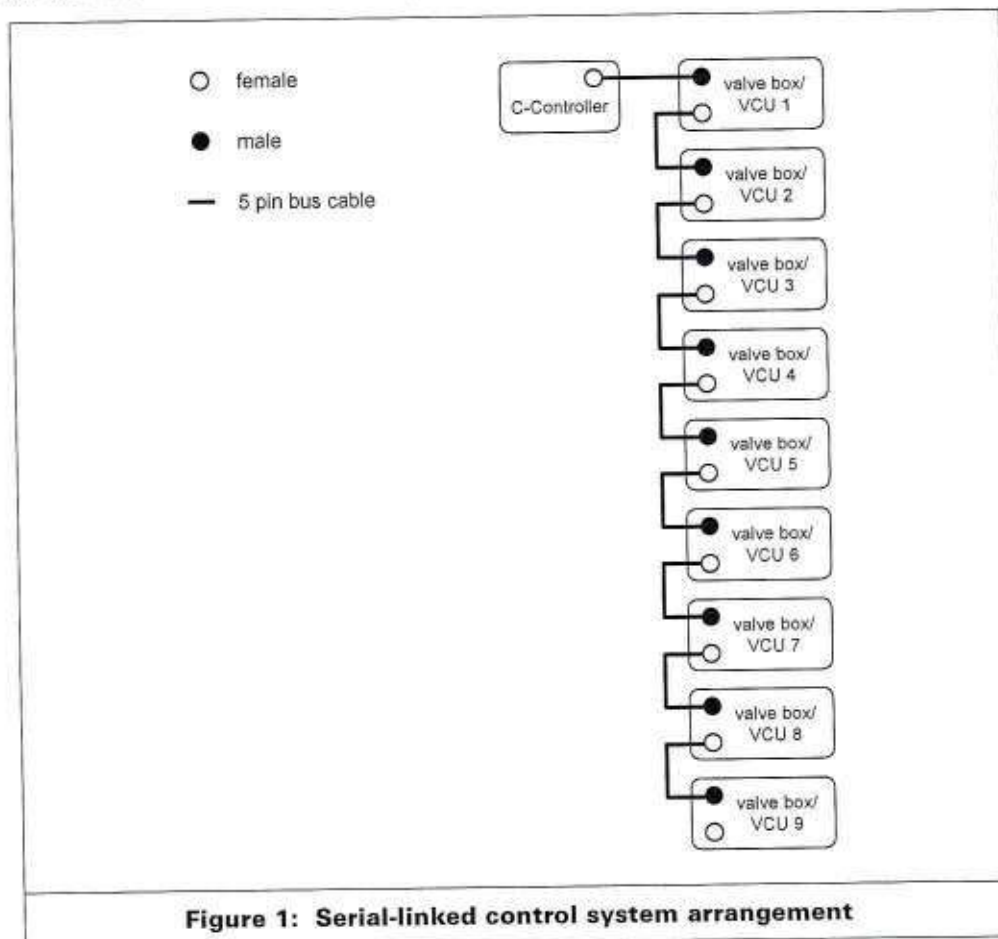

The solenoid valves in a serial-linked control system will fire sequentially as shown in the figure on page 15.

Starting with the controller itself, next the valve box/VCU closest to the controller, etc.

The to be set pulse interval time on the controller will be the desired cycle time, divided by the total number of solenoid valves on the unit.

In formula:

to be set pulse interval time = cycle time/total number of solenoid valves

For further explanation let's state the following:

Cycle time = the time between a cleaning pulse on a filter element and the next pulse on the same filter element.

Valve opening time = is the opening time of the solenoid valve when the cleaning pulse is fired on the filter element.



Default preset value is 100 msec., it should not be changed without consulting your Donaldson contact.

Pulse interval time = the time between a cleaning pulse and the next one on a series sequence

Example:

A 4 bank dust collector as illustrated further, first bank has C-controller with 10 integrated solenoid valves, banks 2 to 4 each have 1 valve box with each 10 integrated solenoid valves. The example is illustrated on the next page.

Total number of solenoid valves = $10 \times 4 = 40$, when the desired cycle time = 120 seconds (2 mins)

Then the interval time should be set to:

Cycle time / Total number of solenoid valves

Interval time = $120s / 40 \text{ solenoids} = 3s$

Note: the minimum set value for the interval time is 2 seconds. In this illustrated case, the minimum cycle time would be then 80 seconds (= $40 \times 2 \text{ sec.}$)



Before setting up the pulse interval time, check that the compressed air supply can deliver the requested compressed air quantity.

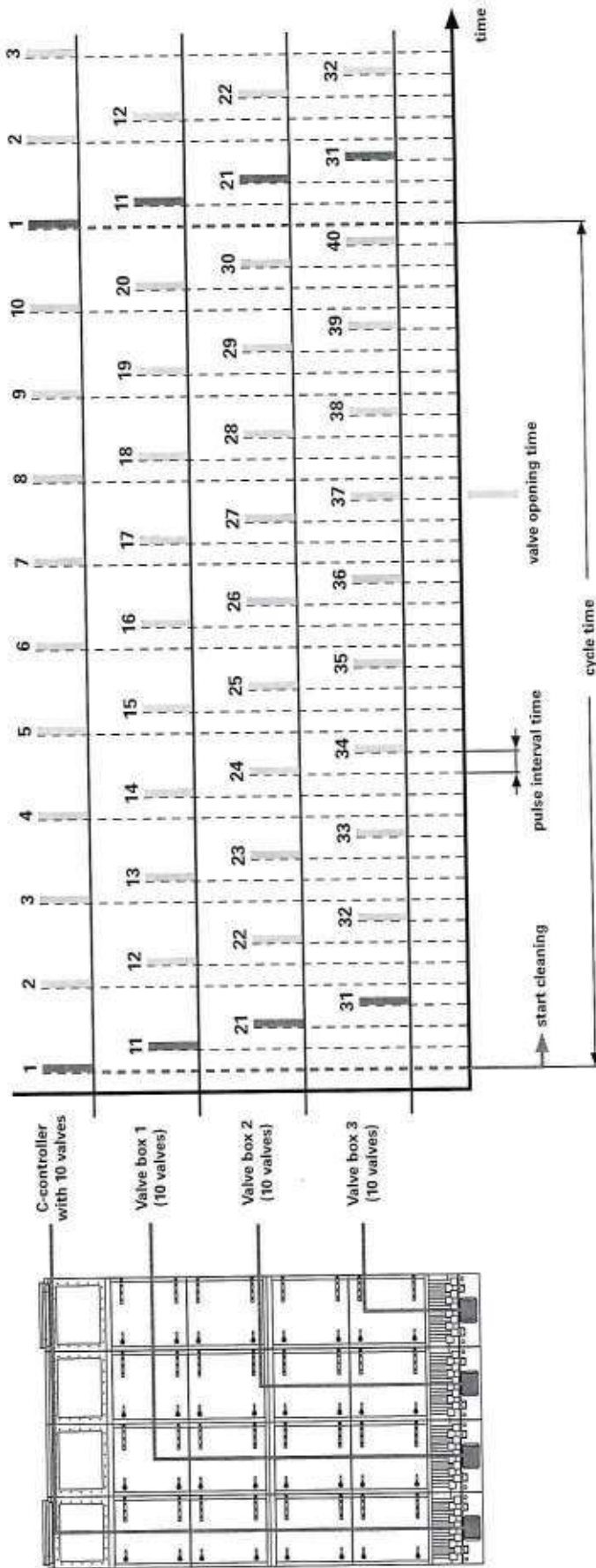

Example illustrated

USER INTERFACE

Home screen

- Cleaning interrupted
- Offline cleaning
- Online cleaning
- Forced cleaning
- Timed cleaning
- Normal operation – fan on



- valve fired
- no valve fired
- no airflow detected
- airflow detected (fan running)



selection

Alarms



An alarm message needs to be manually reset before the alarm message will disappear.

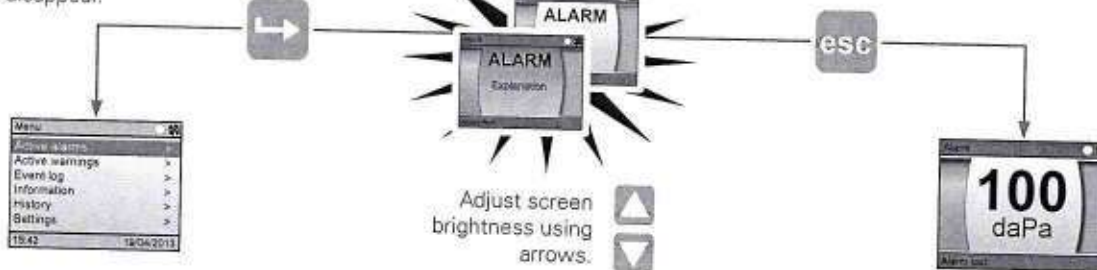

Service alarm >

Too high pressure drop measured. Filters need servicing. Contact your local sales office.

VCU X open circuit >

Valve X (VCU Y) has an open circuit malfunction. Check the solenoid wiring.

VCU X lost >

VCU X is not responding. Check bus cable, if necessary replace the VCU.

MCU X lost >

MCU X is not responding. Check bus cable, if necessary replace the MCU.

4-20mA error [A1] >

The sensor 4-20mA signal is either below 4mA or above 20mA.

Fan alarm >

The fan overload contact tripped. Check the settings & the fan wiring.

Bursting disc alarm >

Bursting disc input open, possibly an explosion has occurred. Check wiring and state of the filter.

Filter stop alarm >

Forced stop on digital input. Check input state.

Emission alarm >

Emission is 20 times higher than initial calibrated situation. Verify filter integrity.

Pressure alarm >

Manifold pressure above or below specs. Please apply correct compressed air supply.

Config alarm >

No filter configuration has been loaded. Please contact your sales rep. to load correct settings.

Wrong fan rotation >

The system has detected wrong fan rotation. Switch over 2 phases of the fan connection.

Data corrupted >

Data corruption has been detected or no configuration file is loaded. The following parameters will be used:

- #VCU/valves/MCUs as detected
- 100 msec. opening time
- Pulse interval = 12 seconds
- Continuous cleaning
- Offline cleaning = 0 cycles
- Low/high ΔP warning = 0

Custom alarm >

The custom alarm input is triggered.

Check the 'Alarm identification table' for more information about the alarms.

Warnings

A warning message will disappear as soon as the warning condition is no longer true.

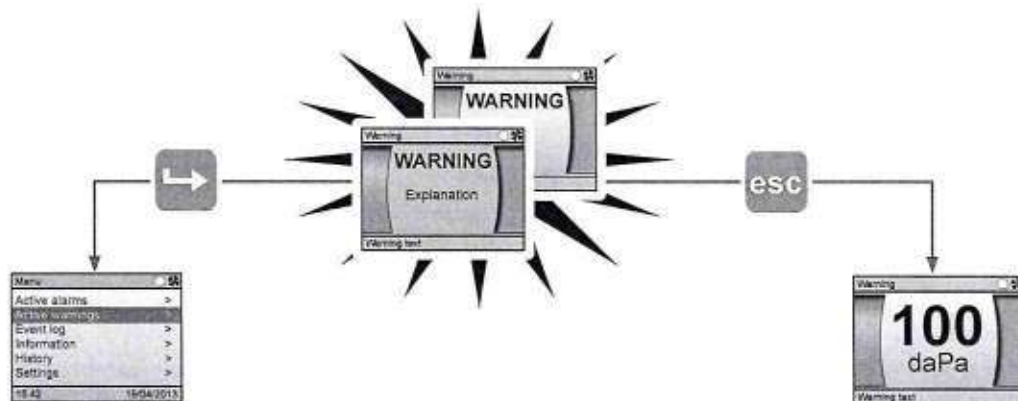

Low ΔP warning >

A low ΔP (flow) over the filter has been detected. Possible causes: ducting is blocked or filter is leaking.

Dustlevel warning >

High dust level detected, empty the dust bin.

Service warning >

Pressure drop over filters remains high while cleaning. Possibly filters are reaching end of life or wrong cleaning settings are applied.

Low battery warning >

Real time battery voltage is low; please renew controller battery. See page 10 for more info.

High ΔP warning >

The ΔP value is over high ΔP value for more than 5 seconds.

Check the 'Warning identification table' for more information about the warnings.

Event log

Register the past events. Last 500 events are showed with time and date indication. all alarms, warnings and events are logged with a date stamp for easy identification.



Information

Overview of the most important settings and parameters

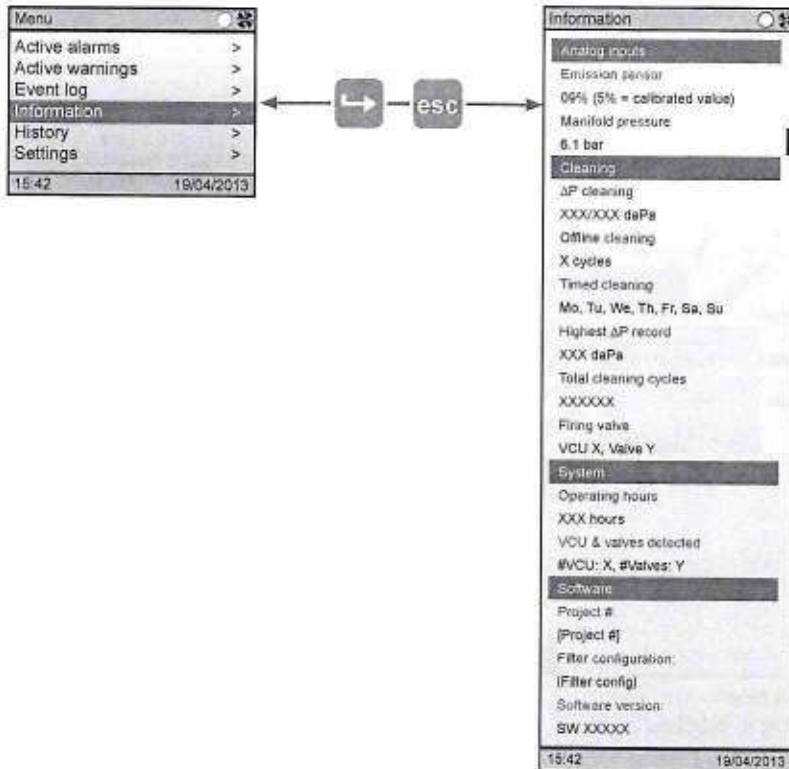

History

History shows a graphical representation of the ΔP History (also other analog sensors history) to see how the dust collector impacts your process and energy consumption.

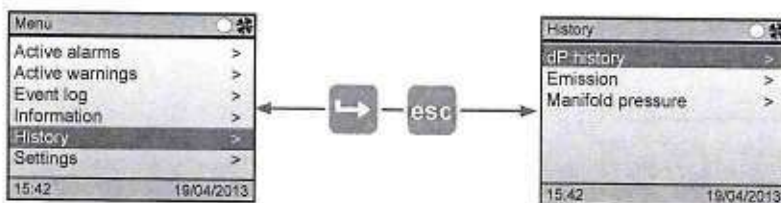

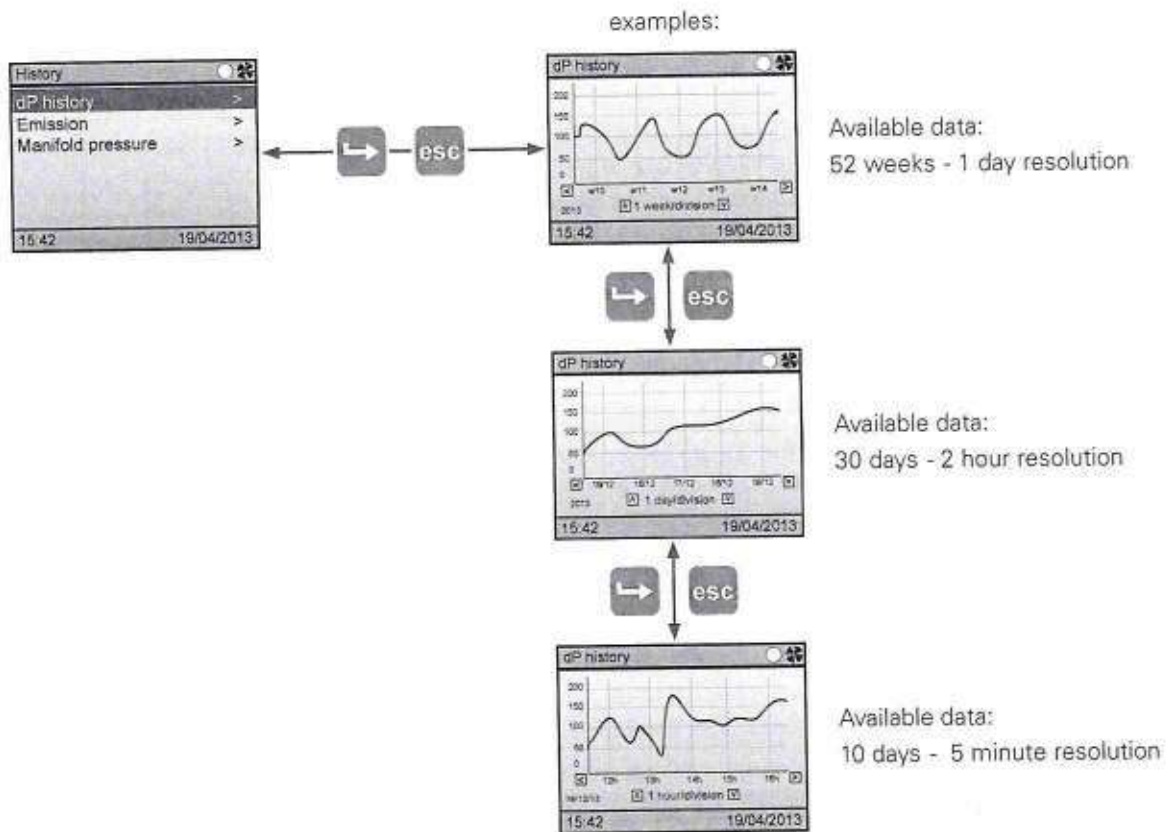

Modifying settings

To modify settings you need to login: go to the menu system by pressing enter on the home screen and navigate down to 'settings'. A PIN code is requested.

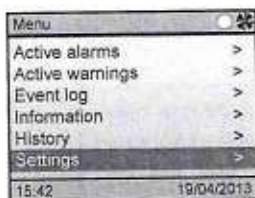

Depending on the code entered you access the operator setting menu or the Donaldson setting menu:

- a. Operator level: change basic settings:
Units / Language / I/O options / # Offline Cycles / Time / Date.
Default PIN code is '9999'
- a. Donaldson level:
Modify cleaning / Input & output / Fan settings / operator PIN / Reset system.
PIN code: Donaldson confidential
Please contact your local sales agent to modify the Donaldson level settings.

GLOSSARY

CLEANING	
Online cleaning	<p>Online cleaning is only performed when fan is detected to be running/air flow is detected.</p> <p>2 online cleaning modes exist:</p> <p>a. ΔP cleaning mode and b. continuous cleaning mode</p> <p>Fan is detected to be running if one of the following three conditions are met:</p> <ul style="list-style-type: none"> • the ΔP over the filter is higher than 12daPa for 5 seconds • the 'fan feedback' input is closed • an MCU is used and an 'on signal' is given
a. ΔP cleaning	<p>The ΔP cleaning mode ensures effective and economical use of the dust collector's reverse-jet cleaning system.</p> <p>The system monitors this build-up of dust by measuring the Differential Pressure (ΔP) across the filter element. The controller will activate the cleaning system when an adjustable preset high level limit 'ΔP_{start}' is reached (while flow is running) and maintain cleaning until the differential pressure has returned to a second adjustable preset low limit 'ΔP_{stop}', the cleaning system will be switched off (after completing its cycle). This process is repeated every time the pressure rises to the high level limit.</p>
b. Continuous cleaning	<p>When the online cleaning mode is set to continuous, the cleaning is always active while fan is detected to be running.</p>
Offline cleaning	<p>When enabled, the function starts a defined number of cleaning cycles to be performed after the fan has been switched off. It is a useful feature to increase the cleaning efficiency as no air flow is running through the filters.</p>
Timed cleaning	<p>The Timed cleaning is an option to activate a continuous cleaning mode based on a configurable day and time, and a defined number of cleaning cycles.</p> <p>When timed cleaning is enabled, you need to set the working days, starting time and number of cleaning cycles in the program menu.</p>
Cycle time	<p>It is the time necessary to pulse all X filter elements one time. Typically, the division of the cycle time by the number of solenoid valves results the interval between cleaning pulses (= pulse interval).</p>
Pulse interval time	<p>The pulse interval time is configurable parameter that defines the time between a cleaning pulse and the next pulse on the next filter element in respect to the series sequence. The default preset value is 12 seconds.</p>
Valve opening time	<p>The valve opening time is a configurable parameter that defines the duration of a compressed air "cleaning" pulse applied on the filter element. On other words, it is the opening time of each solenoid valve when its controller's valve output is active. The default preset value is 100 msec.</p>
Alternate cycle time	

Service warning	The service warning is an alert to the user that the dust collector filter elements are reaching their end of life time. The warning is triggered when the differential pressure over the elements does not drop below the "service warning" setpoint for 15 mins. The default preset value is 80 daPa.
Service alarm	The service alarm is an alert to the user that the dust collector filter elements reached their end of life time. The alarm is triggered when the differential pressure over the elements does not drop below the "service alarm" setpoint for 15 mins. The default preset value is 160 daPa.
Low DP warning	It is an option to alert the user if the system is leaking. When enabled, a warning will be triggered on display when the measured pressure over the filter elements is lower than the configured setpoint for more than 5 seconds while the fan is detected to be running. The setpoint is configurable in the program menu. To disable the low DP warning option, set the setpoint to zero. The default setpoint is zero (disabled).
High DP warning	It is an option to alert the user if the ΔP over the filter elements is higher than the preset setpoint value. The setpoint is configurable in the program menu. To disable, set the setpoint to zero. The default setpoint is 180 daPa.

PROGRAMMABLE INPUT OPTIONS

DIGITAL

Level/emission/ pressure switch	If set, the system will trigger the level/emission/pressure switch alarm or warning if the input is opened for respectively 60/10/120 seconds. When closed (and the alarm is reset) the message will disappear.
Interrupt cleaning	<p>The controller offers the facility to interrupt and restart the cleaning cycle at any point during operation via the interrupt function. This is particularly useful on venting applications where the actual filter operates over a short period of time and a complete cleaning cycle might not take place.</p> <p>The interrupt option can be used to start and stop the cleaning without the controller resetting (the function remembers the last pulse valve fired), ensuring that all filter elements are cleaned. The interrupt function can also be used as a safety feature as it overrides all other cleaning commands; no cleaning will be performed while the interrupt cleaning input is open.</p>
Fan feedback	The fan feedback input can be used to initiate offline cleaning. If set, it is connected to the auxiliary contacts of the main fan contactor. While the fan is running, the input is closed, and the system will perform online cleaning, if the fan stops running, the input is opened and, after a certain time, the system will perform its offline cleaning cycles.
Fan rotation	If set, the system will trigger the fan rotation alarm if the input is opened for 5 seconds. When closed (and the alarm is reset) the message will disappear.
Force cleaning	The forced cleaning input can be used to force the system to clean, regardless of the system status. Once the input is opened, the system will start cleaning until it is closed.

Stop filter	If set, the controller will stop all cleaning activities and stop the fan as soon as the input is opened. An alarm message is shown. As long as the input remains open, neither the cleaning system nor the fan will operate. To reset, the input should be closed and the alarm reset.
Alternate cycle time	If enabled, the secondary frequency drive setpoint will be used when the input is open.
Alternate setpoint VSD	If enabled, the secondary frequency drive setpoint will be used when the input is open.
Custom alarm	If enabled, a custom alarm message is shown when the input is open.

PROGRAMMABLE INPUT OPTIONS

ANALOG	
External ΔP sensor	The C 300 has the option to use a remote ΔP sensor. When set, the 4-20mA input signal overrides the internal ΔP sensor signal.
Emission sensor	If the emission is higher than 25% for 10s, an alarm message is shown. The message disappears when the alarm is reset and the emission was below 19% for 5s.
Manifold sensor	An alarm message is shown when the manifold pressure is 1 bar above or below the required unit compressed air specification for at least 120s. The message is cleared when the alarm is reset & the pressure was within specifications for at least 5s.

PROGRAMMABLE OUTPUT OPTIONS

Cleaning	The relay output is closed if the cleaning system is operating.
Fan-on	The relay output is closed if the fan is running.
Alarm (NO)	The relay output is closed if an alarm is present.
Alarm (NC)	The relay output is opened if an alarm is present (can be used to if 'power off' should also be considered as an alarm).
Warning	The relay output is closed if a warning is present.
Rotary airlock	The contact is closed when the fan or cleaning system is active. The contact has a 30s off-delay for better dust evacuation.
Fan on + cleaning	The relay output is closed if the fan is running and the cleaning system is operating.

FAN SET

Star-delta time	After the fan is switched on, outputs K1 (mains contactor) & K3 (star contactor) are activated. At the end of the star/triangle switch-over time, output K3 (star contactor) is switched off, and output K2 (triangle contactor) is activated.
Run-down time	The system will wait for the run-down time to elapse before starting offline cleaning cycles.

TROUBLESHOOTING

General C300 troubleshooting		
The C300 display is not illuminated and does not react on any command	No power is supplied to the PCB	Check supply circuit for proper voltage, fuses, circuit breakers etc. Replace as required.
	Fuse on PCB module blown	Check wiring connections and replace fuse with correct type.
	Internal controller failure	Replace PCB.
No cleaning	No airflow is detected (fan symbol is not turning)	Online cleaning (continuous or ΔP) only works when airflow is detected ($>12\text{daPa}$ for 5s / fan feedback closed / MCU on). If the ΔP is too low when the filter is running, use the fan feedback input.
	Interrupt active	If the interrupt input is active (shown in the status bar), no cleaning will be performed.
	ΔP below ΔP_{start} set-point	Lower the ΔP start value. Refer to 'Operation' section.
No cleaning pulse(s) although the controller indicates online, offline or forced cleaning in the status bar	Low supply voltage	Check supply voltage.
	Lack of compressed air for cleaning or too high compressed air pressure	Increase compressed air pressure for manifold (required pressure can be found in the dust collector datasheet).
	Diaphragm valve failure	Check for proper valve action and repair or replace if necessary.
	The cleaning system configuration is not identified to the controller	Apply the valve detection procedure.
No offline cleaning	Offline cleaning is not set up	Set the number of offline cleaning cycles higher than 0.
	Flow is still running	The ΔP should be below 12daPa for the system to stop online cleaning, if the ΔP remains above this value, the fan feedback input can be used to force the system in offline mode.
	Broken coil of the solenoid valve	Check the solenoid coil and replace it if necessary.
Weak pulses	No connection between the controller and the solenoid valves/VCU	Check the continuity of bus connection between the controller and the solenoid valves/VCU. Replace the VCU if necessary.
	Insufficient air supply	Check the manifold pressure (required pressure can be found in the dust collector datasheet).
	Restriction in pneumatic tubing	Check the tubing between the solenoids & the diaphragm valves.

Push button malfunction	No connection between the display buttons and the controller	Check the connection between the display buttons and controller main printed circuit board.
	Incorrect parameter file uploaded	Check if MCU is configured to the controller. This can be checked by pressing right and left arrow buttons simultaneously for 5 seconds until you see the test page. If it shows that the MCU is not found/connected, ask your Donaldson sales contact to upload the correct parameter file to the controller.
Incorrect ΔP reading	ΔP pressure lines dirty or with kinks	Drain ΔP pressure lines. Clean the pressure lines with compressed air (only in direction of filter, never in direction of sensor). Check the pressure lines for kinks.
	ΔP pressure lines loose	Check the pressure lines for leaks.
		Disconnect the ΔP hoses from the pressure transducer on the controller's PCB. If the controller still shows readings, the pressure transducer is malfunction. Replace the controller PCB if necessary.

C300 equipped with motor control module

Fan does not start	Main switch on control box open	Turn main switch to ON-position.
	Fan alarm (alarm A6)	The automatic circuit breaker is tripped. Reset it. Check the overload setting, check if the system has sufficient flow, check for short circuits & check if the motor is faulty.
	MCU is not responding	The motor control unit is not responding. Check the bus cable, replace the MCU when necessary.
	Electrical supply fault	Check supply circuit for proper voltage, fuses, circuit breakers etc. Replace as required.
The automatic circuit breaker switches off while the fan starts up	Delay time between star and triangle is too short	Increase the star-delta change-over time.
	Incorrect fan overload setting	Check fan overload setting in the controlbox.
The fan only works in star operation when the unit is switched on; in triangle the fan stops	The triangle contactor is defective	Change the delta contactor (see wiring diagram supplied with the controller).
	Incorrect wiring to fan	Check wiring from control box to fan.

ALARM IDENTIFICATION TABLE

Alarm	Reason / cause	Field root cause	Solution
[A1] Service Alarm	The alarm is triggered when the measured pressure over the filter elements is higher than the configured setpoint for more than 15 mins. The default service alarm setpoint is 160 daPa	Saturated filter elements	Replace the filter elements
		Wrong cleaning settings configuration	Check the cleaning settings and modify if needed
[A2] Valve "X" open circuit	The alarm is triggered when a configured/detected solenoid valve has an open circuit.	Broken solenoid coil	Change the coil
		No connection between the controller and the solenoid valve	Check the continuity of the wiring between the controller and the solenoid valve
		The cleaning system is not identified by the controller	Apply the auto valve detection procedure
[A3] VCU "X" lost	The alarm is triggered when the controller loses the connection with a configured/detected VCU. Main common reason, the controller is connected to the cleaning system without applying the auto valve detection procedure.	No connection between the controller and the solenoid valve	Check the continuity of the bus cable connection between the controller and the VCU/Valve box
		The controller is connected to unconfigured VCU	Apply the auto valve detection procedure
[A4] MCU "X" lost	The alarm is triggered when the controller loses the connection with a configured/detected MCU. Main common reason, the controller is connected to the cleaning system without applying the auto valve detection procedure.	No connection between the controller and the MCU	Check the continuity of the bus cable connection between the controller and the MCU
		The controller is connected to unconfigured MCU	Apply the auto valve detection procedure
[A5] 4-20 mA error AI "X"	The alarm is triggered when the controller (AI terminals) receives 4-20mA signal either below 4mA or above 20mA. Main common reason, no sensor is connected to the analog input while it is activated.	Analog input is enabled, no sensor is connected to the AI terminals	Disable the analog input in case no sensor is connected
		No connection between the controller and the sensor	Check the continuity of wiring between the controller and the sensor
		Broken sensor	Check the sensor and replace if necessary.
[A6] Fan alarm	The alarm is triggered when the MCU's "fan alarm" digital input is opened. Main common reason, the fan overload contact is tripped. The fan overload NO contact is connected to the MCU terminals (11,12) to show the status of the automatic circuit breaker.	The automatic circuit breaker is tripped	Reset the automatic circuit breaker. Check the overload setting, check if the system has sufficient flow, check for short circuits & check if the motor is faulty.

Alarm	Reason / cause	Field root cause	Solution
[A7] Data corruption	The alarm is triggered when no filter configuration has been loaded to the controller or data corruption has been detected.		Upload a new parameter file to the controller
[A8] Bursting disc alarm	The alarm is triggered when the controller's "bursting disc" digital input is opened. The bursting disc signaling unit is connected to the controller bursting disc input terminals {C200: 11,12} {C300: 17,18}	The bursting disc input terminals are opened	Close/bridge the bursting disc input terminals, in case no bursting disc signaling unit is used in the unit
		The bursting disc signaling wires are not connected to the controller's input terminals or an explosion has occurred	Check the wiring between the signaling unit and the controller. Check the state of the filter. Check the signalling unit and replace if necessary.
[A9] Filter stop	The alarm is triggered when the controller's "filter stop" digital input is opened.	Digital input is programmed to "filter stop" and the input contacts are opened	Disable the digital input in case no "filter stop" switch is connected. Check the wiring to the input in case the input is connected to other system.
[A10] Emission alarm	The alarm is triggered when the controller's analog input is programmed to "Emission sensor" and the input receives signal higher than 8mA for more than 10 seconds. The alarm can also be triggered when the controller's digital input is programmed to "Emission switch" and the input is opened for 10 seconds	Dust leakage	Check the filter elements status, otherwise identify the leakage source.
		Digital input is programmed to "Emission switch" and the input contacts are opened	Disable the digital input in case no Emission switch is connected. Check the wiring to the input in case the input is connected to an Emission switch
[A11] Pressure alarm	The alarm is triggered when the controller's analog input is programmed to "Manifold sensor" and the input is higher or lower than the manifold pressure setpoint by 1 bar receives signal higher than 8mA for more than 120 seconds. The alarm can also be triggered when the controller's digital input is programmed to "pressure switch" and the input is opened for 120 seconds	Incorrect manifold pressure supply	Check the manifold air supply pressure regulator
		Digital input is programmed to "pressure switch" and the input contacts are opened	Disable the digital input in case no pressure switch is connected. Check the wiring to the input in case the input is connected to a pressure switch
[A12] Custom alarm	The alarm is triggered when the controller's "custom alarm" digital input is opened than 5 seconds.	Digital input is programmed to "custom alarm" and the input contacts are opened	Disable the digital input in case no "custom alarm" switch is connected.
			Check the wiring to the input in case the input is connected to other system.
[A13] Configuration alarm	The alarm is triggered when no filter configuration has been loaded to the controller.		Upload a new parameter file to the controller

Alarm	Reason / cause	Field root cause	Solution
[A14] Wrong fan rotation	The alarm is triggered when the controller's "fan rotation" digital input is opened for 5 seconds.	Digital input is programmed to "fan rotation" and the input contacts are opened	Disable the digital input in case no "fan rotation" switch is connected.
			Check the wiring to the input in case the input is connected to other system

WARNING IDENTIFICATION TABLE

Warning	Reason / cause	Field root cause	Solution
[W1] Low ΔP warning	The warning is triggered when the measured pressure over the filter elements is lower than the configured setpoint for more than 5 seconds while the fan is running. To disable the low DP warning option, set the setpoint to zero. The default low DP warning setpoint is zero (disabled)	Ducting is blocked	Check the ducting state
		The system is leaking	Check the filter elements status or any other leakage source in the system
[W2] Service warning	The warning is triggered when the measured pressure over the filter elements is higher than the configured setpoint for more than 15 mins. The default service warning setpoint is 80 daPa	Saturated filter elements	Replace the filter elements
		Wrong cleaning settings configuration	Check the cleaning settings and modify it if needed
[W3] Dustlevel warning	The warning is triggered when the controller's digital input is programmed to "Level switch" and the input is opened for 60 seconds	High dust level in the unit's bin/hopper	Check the dust level in the unit's bin/hopper
		Digital input is programmed to "Level switch" and the input contacts are opened	Disable the digital input in case no level switch is connected. Check the wiring to the input in case the input is connected to a level switch
[W4] Low battery warning	The warning is triggered when the controller detects that real time battery voltage is low		Renew the controller battery. Check the manual for more information.
[W5] High ΔP warning	The warning is triggered when the measured pressure over the filter elements is higher than the configured setpoint for more than 5 seconds. This is available only for C300. The default high DP warning setpoint is 180 daPa	Broken filter elements	Replace the filter elements
		Wrong cleaning settings configuration	Check the cleaning settings and modify it if needed

Directives only applicable as defined by the Scope of Delivery.

EG-Konformitätserklärung EU-Declaration of Conformity / Déclaration de conformité CEE

nach Artikel 10.1 der Richtlinie 2014/30/EG und 2014/35/EG
acc. to Article 10.1 of the 2014/30/EG and 2014/35/EG
selon l'article 10.1 de la directive 2014/30/EG et 2014/35/EG

Wir,
We,
Nous, **Reco GmbH, Junkersring 11, 53844 Troisdorf, Allemagne**

Name und Anschrift des Herstellers oder des in der EU niedergelassenen Inverkehrbringers
Name and address of the manufacturer or of the introducer of the product who is established in the EU
Nom et adresse du fabricant ou la personne résidant dans la CEE qui introduit le sous-dit produit de la CEE

erklären in alleiniger Verantwortung, dass das Produkt
herewith take the sole responsibility to confirm that the product
soussignés déclarons de notre seule responsabilité que ce produit

C300

Typenbezeichnung und ggf. Artikel Nummer
Type designation and, if applicable, article no.
Type, nom et - si nécessaire - n° d'article du produit

mit den folgenden Normen bzw. normativen Dokumenten übereinstimmt.
is in accordance with the following standards or standardized documents.
est conforme aux normes ou spécifications Européennes suivantes.

1	DIN EN 61000-3-2:2015-03	EMV Grenzwerte für Oberschwingungsströme
2	DIN EN 61000-3-3:2014-03	EMV Grenzwerte – Begrenzung von Spannungsänderungen
3	DIN EN 61000-4-2:2009-12	EMV Störfestigkeit gegen die Entladung statischer Elektrizität
4	DIN EN 61000-4-3:2011-04	EMV Störfestigkeit gegen hochfrequente elektromagnetische Felder
5	DIN EN 61000-4-4:2013-04	EMV Störfestigkeit gegen schnelle transiente elektrische Störgrößen
6	DIN EN 61000-4-5:2015-03	EMV Störfestigkeit gegen Stoßspannung
7	DIN EN 61000-4-6:2014-08	EMV Störfestigkeit gegen leitungsgeführte Störgrößen
8	DIN EN 61000-4-8:2010-11	EMV Störfestigkeit gegen Magnetfelder
9	DIN EN 61000-4-11:2005-02	EMV Störfestigkeit gegen Spannungseinbrüche
10	DIN EN 61000-6-2:2011-08	EMV Störfestigkeit für Industriebereiche
11	DIN EN 61000-6-4:2011-09	EMV Störaussendung
12	DIN EN 55011:2011-04	Funkstörungen – Grenzwerte und Messverfahren
13	DIN EN 60204-1:2010-05	elektrische Ausrüstung von Maschinen

Die Betriebsbedingungen und Einsatzumgebungen gemäß Dokumentation sind vorauszusetzen.
The operating conditions and installation arrangements have to be presumed according documentation.
Les conditions d'opération et d'installation suivantes sont à respecter.

53844 Troisdorf, den 19.04.2016

Ort und Datum der Ausstellung
Place and date of issue
Lieu et date

i.V. Thomas Büttner

Name und Unterschrift
Name and signature
Nom et signature

RECO Gesellschaft für
Industrie-Agung mbH
Junkersring 11
53844 Troisdorf - Germany
Tel.: +49(0)2241/307 04-0

Directives only applicable as defined by the Scope of Delivery.

	<p>EG-Konformitätserklärung gemäß Explosionsschutzrichtlinie 2014/34 EG</p> <p>EU-Declaration of Conformity according to ATEX Directive 2014/34 EC</p>
---	--

Hersteller: RECO GmbH
Junkersring 11
53844 Troisdorf
Deutschland

Telefon: +49 2241 39704-0

E-Mail: info@reco-gmbh.com
www.reco-gmbh.com

Manufacturer: RECO GmbH
Junkersring 11
53844 Troisdorf
Germany

Phone: +49 2241 39704-0

e-mail: info@reco-gmbh.com
www.reco-gmbh.com

erklärt, dass die explosionsgeschützt ausgeführten

declares that the explosion-proof systems, designated

<p>Bezeichnung:</p> <p style="text-align: center;">Typ: C300</p>	<p>Denomination:</p> <p style="text-align: center;">Type: C300</p>
<p>Kennzeichnung:</p> <p style="text-align: center;">Ex II 3D Ex tc IIIC T85°C Dc Ambient Temp. -10 / +60°C</p>	<p>Identification:</p> <p style="text-align: center;">Ex II 3D Ex tc IIIC T85°C Dc Ambient Temp. -10 / +60°C</p>

Geräte im Sinne des Artikels 1 (3) der Richtlinie 94/9/EG sind und die grundlegenden Sicherheits- und Gesundheitsanforderungen gemäß Anhang II der Richtlinie 94/9/EG erfüllen. Die grundlegenden Sicherheits- und Gesundheitsanforderungen werden erfüllt in Übereinstimmung mit folgenden Normen:

EN 60079-0 (2014)
EN 60079-31 (2014)

Es wird vorausgesetzt, dass der Einbau und der Betrieb der Geräte nur ihrer bestimmungsgemäßen Verwendung entsprechen. Informationen zur bestimmungsgemäßen Verwendung sind aus der Betriebsanleitung und dem Spezifikationsblatt zum Explosionsschutz zu entnehmen.

are devices as defined in article 1 (3) of the standard RL 94/9/EC and that they meet the fundamental health and safety requirements according to the appendix II of Directive 94/9/EC. The fundamental health and safety requirements are met in accordance with the following standards:

EN 60079-0 (2014)
EN 60079-31 (2014)

It is presumed that the devices are mounted and operated in accordance with their intended use. The intended use is described in the operation instructions, the specification sheet and in the supplement manual for explosion protection.

Troisdorf, den 31.03.2016

Thomas Büttner

**RECO Gesellschaft für
Industriefilter-Regalung mbH**
Junkersring 11
53844 Troisdorf - Germany
Tel.: +49(0)2241/397 04-0

Ort, Datum / Place, Date

Name und Unterschrift / Name and signature

Stempel / Stamp

I.V. Thomas Büttner
Engineering Manager RD

